

Wilo-WiBooster

		Project:					
		Engineer:					
		Contractor:					
		Submitted By:			Date:		
		Approved By:			Date:		
Tag #	Model #	Flow	Head	HP/Pump	Cycle	Phase	Voltage
	WiBooster 4/321/B			5	60Hz		

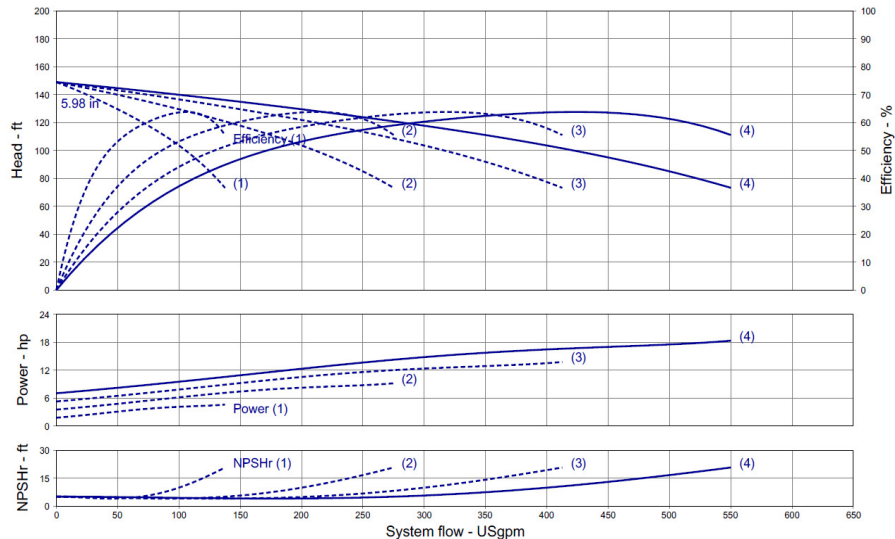

Product Info

Brand	Wilo
Product Description	WiBooster 4/321/B
Construction Materials	
Pump Volute	304 Stainless Steel
Impeller	304 Stainless Steel
Shaft	304 Stainless Steel
Elastomers	EPDM
Isolation Valves	Butterfly, SS Stem/Disc, EPDM Seal
Manifolds	304 Stainless Steel, ANSI-Flanged
Check Valves	Stainless Steel, Non-Slam, Plunger Type with EPDM Seal
Mechanical Seal	Type 21
Pressure Transducers	316 Stainless Steel
Pressure Gauges	304/316 Stainless Steel
System Base	Plated Steel
Vibration Isolators	Neoprene, Height-Adjustable

Motor Data

Motor Power Supply	3~208-230/460/575V
Enclosure	ODP/TEFC
Efficiency	NEMA Premium
Horsepower/Pump	5
Enclosure Material	Rolled Steel/Cast Iron
Motor Protection Class	IP54
Insulation Class	F

Hydraulic Data

Max Operating Pressure	150 PSI
Max Inlet Pressure	75 PSI
Min. Fluid Temp.	40°F
Max Fluid Temp.	140°F
Min. Ambient Temp	32°F
Max. Ambient Temp	104°F

Panel Info

Power Supply	1~230, 3~208-230/460/575
Enclosure	NEMA 12 (3R Available on Request)
Standard	Meets UL 508A
VFD's	Danfoss FC-51 /FC-101

PLC Info

User Interface	7" Color Touchscreen
Display Resolution	800 x 480 Pixels
Supply Voltage	24VDC
Max Current	320mA @24V
Analog Inputs/Outputs	9/2
Digital Inputs/Outputs	18/17
Communications	ModBUS Standard (BacNET, LONWorks Optional)
Ethernet Port	RJ45 (10/100Mbps)
Additional Ports	USB 2.0, Micro-SD

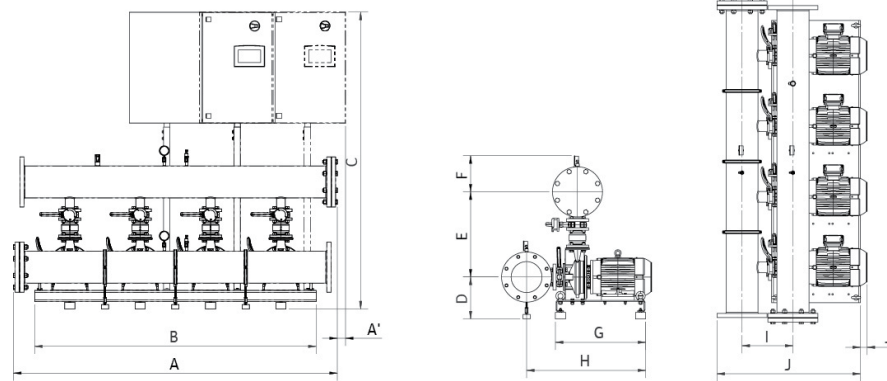

Dimensions

	Full Flow Connection (in)				Half Flow Connection (in)			
	1-3-230	3-208-230	3-460	3-575	1-3-230	3-208-230	3-460	3-575
System Connection (150#)	6	6	6	6	4	4	4	4
A	87.2	87.2	87.2	87.2	86.9	86.9	86.9	86.9
A ₁	3.9	x	x	x	3.9	x	x	x
B	76	76	76	76	76	76	76	76
C	75	75	75	75	75	75	75	75
D	10.2	10.2	10.2	10.2	10.2	10.2	10.2	10.2
E	21.7	21.7	21.7	21.7	19.7	19.7	19.7	19.7
F	8.7	8.7	8.7	10	7.7	7.7	7.7	9
G	24.4	24.4	24.4	24.4	24.4	24.4	24.4	24.4
H	31	31	31	31	29	29	29	29
I	11.8	11.8	11.8	11.8	9.8	9.8	9.8	9.8
J	36.3	36.3	36.3	36.3	33.3	33.3	33.3	33.3
J ₁	x	x	x	x	x	x	x	x
Panel Dimensions (HxWxD)	30x39x12	30x30x10	30x30x10	30x30x10	30x39x12	30x30x10	30x30x10	30x30x10
Full Load Amps (per pump)	13.2-12.0	13.2-12.0	6.0	4.8	13.2-12.0	13.2-12.0	6.0	4.8
Panel Weight (lbs)	137.95	137.95	139	190	137.95	137.95	139	190
Pump Weight (ea - lbs)	124	124	124	124	124	124	124	124
System Weight (lbs)	1370	1370	1370	1420	1275	1275	1275	1325

Approval Stamp