

Wilo-WiBooster

		Project:					
		Engineer:					
		Contractor:					
		Submitted By:			Date:		
		Approved By:			Date:		
Tag #	Model #	Flow	Head	HP/Pump	Cycle	Phase	Voltage
	WiBooster 3/323/C			3	60Hz		

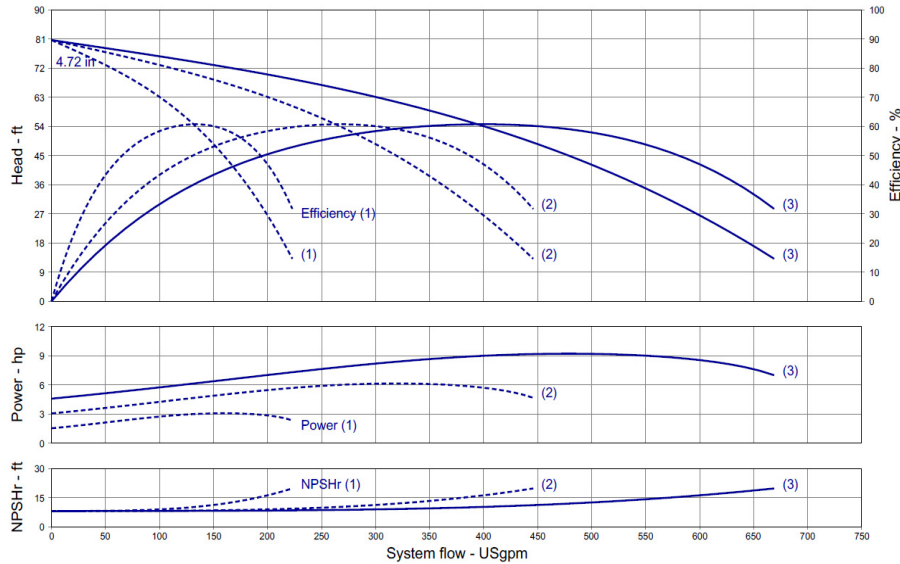

Product Info

Brand	Wilo
Product Description	WiBooster 3/323/C

Construction Materials

Pump Volute	304 Stainless Steel
Impeller	304 Stainless Steel
Shaft	304 Stainless Steel
Elastomers	EPDM
Isolation Valves	Butterfly, SS Stem/Disc, EPDM Seal
Manifolds	304 Stainless Steel, ANSI-Flanged
Check Valves	Stainless Steel, Non-Slam, Plunger Type with EPDM Seal
Mechanical Seal	Type 21
Pressure Transducers	316 Stainless Steel
Pressure Gauges	304/316 Stainless Steel
System Base	Plated Steel
Vibration Isolators	Neoprene, Height-Adjustable

Motor Data

Motor Power Supply	3-208-230/460/575V
Enclosure	ODP/TEFC
Efficiency	NEMA Premium
Horsepower/Pump	3
Enclosure Material	Rolled Steel/Cast Iron
Motor Protection Class	IP54
Insulation Class	F

Hydraulic Data

Max Operating Pressure	150 PSI
Max Inlet Pressure	75 PSI
Min. Fluid Temp.	40°F
Max Fluid Temp.	140°F
Min. Ambient Temp	32°F
Max. Ambient Temp	104°F

Panel Info

Power Supply	1-230, 3-208-230/460/575
Enclosure	NEMA 12 (3R Available on Request)
Standard	Meets UL 508A
VFD's	Danfoss FC-51 /FC-101

PLC Info

User Interface	7" Color Touchscreen
Display Resolution	800 x 480 Pixels
Supply Voltage	24VDC
Max Current	320mA @24V
Analog Inputs/Outputs	9/2
Digital Inputs/Outputs	18/17
Communications	ModBUS Standard (BacNET, LONWorks Optional)
Ethernet Port	RJ45 (10/100Mbps)
Additional Ports	USB 2.0, Micro-SD

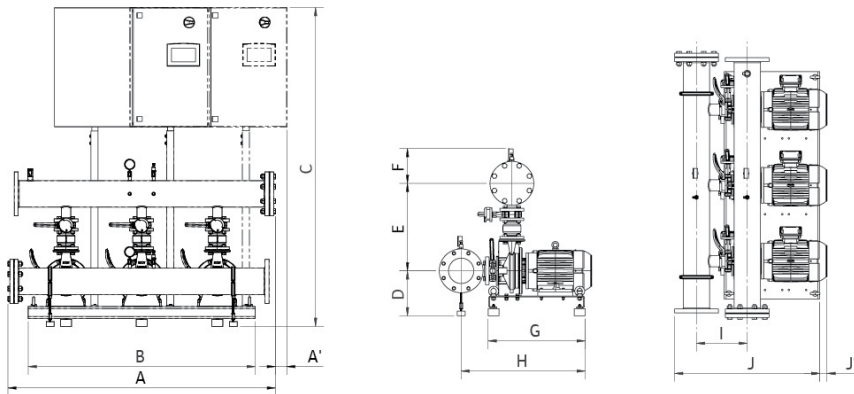

Dimensions

System Connection (150#)	Full Flow Connection (in)				Half Flow Connection (in)			
	1-3-230	3-208-230	3-460	3-575	1-3-230	3-208-230	3-460	3-575
A	67.2	67.2	67.2	67.2	66.9	66.9	66.9	66.9
A ₁	x	x	x	x	x	x	x	x
B	57	57	57	57	57	57	57	57
C	75	75	67	75	75	75	67	75
D	9.4	9.4	9.4	9.4	9.4	9.4	9.4	9.4
E	21.4	21.4	21.4	21.4	19.4	19.4	19.4	19.4
F	8.7	8.7	8.7	10	7.7	7.7	7.7	9
G	24.4	24.4	24.4	24.4	24.4	24.4	24.4	24.4
H	31.1	31.1	31.1	31.1	29.1	29.1	29.1	29.1
I	12	12	12	12	10	10	10	10
J	36.4	36.4	36.4	36.4	33.4	33.4	33.4	33.4
J ₁	x	x	x	x	x	x	x	x
Panel Dimensions (HxWxD)	30X24X10	30X24X10	24X24X8	30X30X10	30X24X10	30X24X10	24X24X8	30X30X10
Full Load Amps (per pump)	8.2-7.4	8.2-7.4	3.7	3.0	8.2-7.4	8.2-7.4	3.7	3.0
Panel Weight (lbs)	111.6	111.6	83	150	111.6	111.6	83	150
Pump Weight (ea - lbs)	118	118	118	118	118	118	118	118
System Weight (lbs)	1085	1085	1035	1125	995	995	945	1035

Approval Stamp