

Wilo-WiBooster

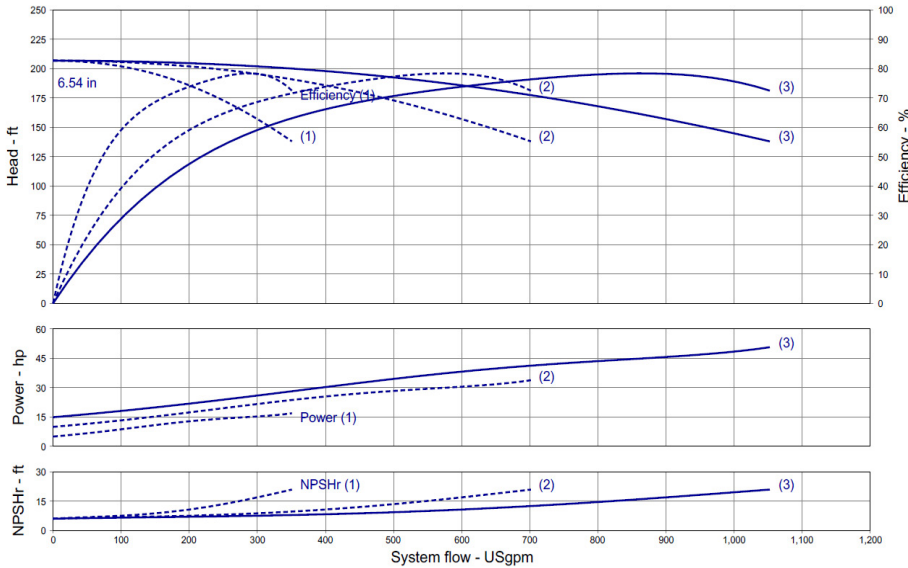

Project:	
Engineer:	
Contractor:	
Submitted By:	Date:
Approved By:	Date:

Tag #	Model #	Flow	Head	HP/Pump	Cycle	Phase	Voltage
	WiBooster 3/328/C			15	60Hz		



Product Info

Brand	Wilo
Product Description	WiBooster 3/328/C

Construction Materials

Pump Volute	304 Stainless Steel
Impeller	304 Stainless Steel
Shaft	304 Stainless Steel
Elastomers	EPDM
Isolation Valves	Butterfly, SS Stem/Disc, EPDM Seal
Manifolds	304 Stainless Steel, ANSI-Flanged
Check Valves	Stainless Steel, Non-Slam, Plunger Type with EPDM Seal
Mechanical Seal	Type 21
Pressure Transducers	316 Stainless Steel
Pressure Gauges	304/316 Stainless Steel
System Base	Plated Steel
Vibration Isolators	Neoprene, Height-Adjustable

Motor Data

Motor Power Supply	3-208-230/460/575V
Enclosure	ODP/TEFC
Efficiency	NEMA Premium
Horsepower/Pump	15
Enclosure Material	Rolled Steel/Cast Iron
Motor Protection Class	IP54
Insulation Class	F

Hydraulic Data

Max Operating Pressure	150 PSI
Max Inlet Pressure	75 PSI
Min. Fluid Temp.	40°F
Max Fluid Temp.	140°F
Min. Ambient Temp	32°F
Max. Ambient Temp	104°F

Panel Info

Power Supply	1-230, 3-208-230/460/575
Enclosure	NEMA 12 (3R Available on Request)
Standard	Meets UL 508A
VFD's	Danfoss FC-51 / FC-101

PLC Info

User Interface	7" Color Touchscreen
Display Resolution	800 x 480 Pixels
Supply Voltage	24VDC
Max Current	320mA @24V
Analog Inputs/Outputs	9/2
Digital Inputs/Outputs	18/17
Communications	ModBUS Standard (BacNET, LONWorks Optional)
Ethernet Port	RJ45 (10/100Mbps)
Additional Ports	USB 2.0, Micro-SD

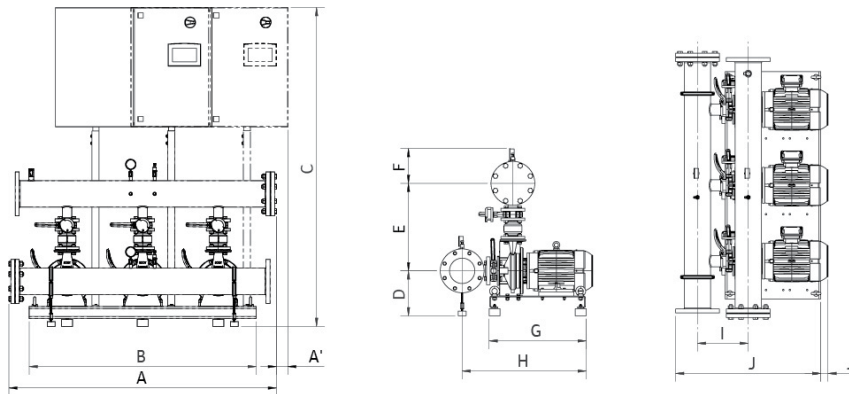

Dimensions

System Connection (150#)	Full Flow Connection (in)			Half Flow Connection (in)				
	1-3-230	3-208-230	3-460	3-575	1-3-230	3-208-230	3-460	3-575
A	x	67.2	67.2	x	x	65.2	65.2	x
A ₁	x	2.8	x	x	x	4.4	x	x
B	x	57	57	x	x	57	57	x
C	x	75	75	x	x	75	75	x
D	x	11.7	11.7	x	x	11.7	11.7	x
E	x	21.9	21.9	x	x	21.9	21.9	x
F	x	8.7	8.7	x	x	8.7	8.7	x
G	x	24.4	24.4	x	x	24.4	24.4	x
H	x	31.2	31.2	x	x	31.2	31.2	x
I	x	12.75	12.75	x	x	12.75	12.75	x
J	x	36.4	36.4	x	x	36.4	36.4	x
J ₁	x	1.8	1.8	x	x	1.8	1.8	x
Panel Dimensions (HxWxD)	x	30x39x12	30x30x10	x	x	30x39x12	30x30x10	x
Full Load Amps (per pump)	x	37.4-34.0	17.0	x	x	37.4-34.0	17.0	x
Panel Weight (lbs)	x	201.7	166.5	x	x	201.7	166.5	x
Pump Weight (ea - lbs)	x	312	312	x	x	312	312	x
System Weight (lbs)	x	1430	1395	x	x	1430	1395	x

Approval Stamp