

Wilo-WiBooster

		Project:					
		Engineer:					
		Contractor:					
		Submitted By:			Date:		
		Approved By:			Date:		
Tag #	Model #	Flow	Head	HP/Pump	Cycle	Phase	Voltage
	WiBooster 2/320/B			3	60Hz		

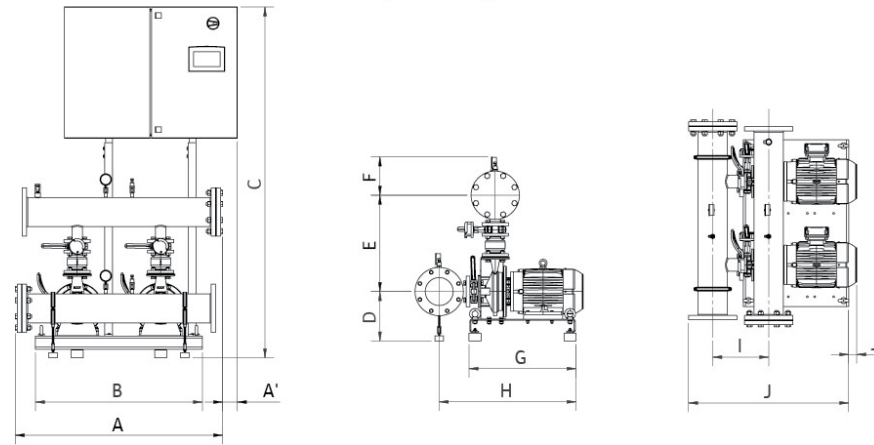
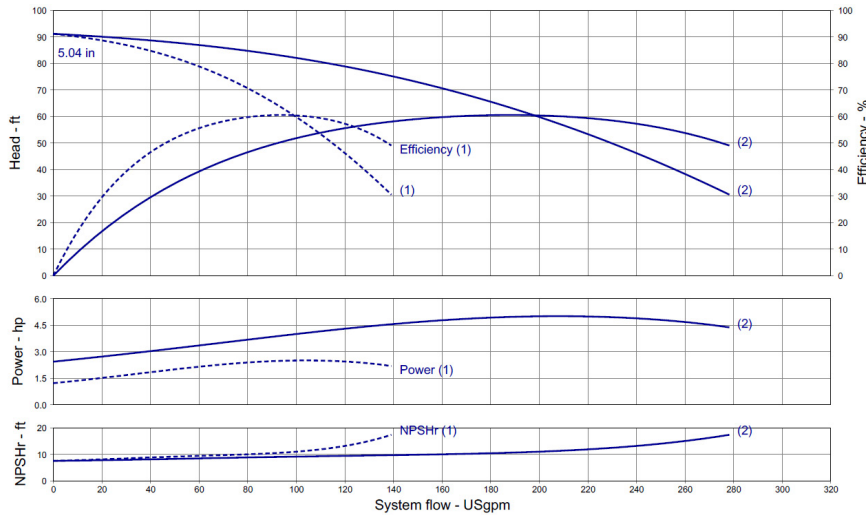

Dimensions	Full Flow Connection (in)				Half Flow Connection (in)			
	1-3-230	3-208-230	3-460	3-575	1-3-230	3-208-230	3-460	3-575
System Connection (150#)	4	4	4	4	3	3	3	3
A	46.9	46.9	46.9	46.9	46.9	46.9	46.9	46.9
A ₁	x	x	x	x	x	x	x	x
B	38	38	38	38	38	38	38	38
C	75	75	67	75	75	75	67	75
D	9.4	9.4	9.4	9.4	9.4	9.4	9.4	9.4
E	19.7	19.7	19.7	19.7	18	18	18	18
F	7.7	7.7	7.7	9	7.2	7.2	7.2	8.5
G	24.4	24.4	24.4	24.4	24.4	24.4	24.4	24.4
H	29.1	29.1	29.1	29.1	28.1	28.1	28.1	28.1
I	9.8	9.8	9.8	9.8	8.8	8.8	8.8	8.8
J	33.4	33.4	33.4	33.4	31.6	31.6	31.6	31.6
J ₁	x	x	x	x	x	x	x	x
Panel Dimensions (HxWxD)	30X24X10	30X24X10	24X24X8	30X24X10	30X24X10	30X24X10	24X24X8	30X24X10
Full Load Amps (per pump)	8.2-7.4	8.2-7.4	3.7	3.0	8.2-7.4	8.2-7.4	3.7	3.0
Panel Weight (lbs)	104.3	104.3	78.8	130	104.3	104.3	78.8	130
Pump Weight (ea - lbs)	112	112	112	112	112	112	112	112
System Weight (lbs)	700	700	675	725	660	660	635	685

Product Info

Brand	Wilo
Product Description	WiBooster 2/320/B
Construction Materials	
Pump Volute	304 Stainless Steel
Impeller	304 Stainless Steel
Shaft	304 Stainless Steel
Elastomers	EPDM
Isolation Valves	Butterfly, SS Stem/Disc, EPDM Seal
Manifolds	304 Stainless Steel, ANSI-Flanged
Check Valves	Stainless Steel, Non-Slam, Plunger Type with EPDM Seal
Mechanical Seal	Type 21
Pressure Transducers	316 Stainless Steel
Pressure Gauges	304/316 Stainless Steel
System Base	Plated Steel
Vibration Isolators	Neoprene, Height-Adjustable

Motor Data

Motor Power Supply	3-208-230/460/575V
Enclosure	ODP/TEFC
Efficiency	NEMA Premium
Horsepower/Pump	3
Enclosure Material	Rolled Steel/Cast Iron
Motor Protection Class	IP54
Insulation Class	F

Hydraulic Data

Max Operating Pressure	150 PSI
Max Inlet Pressure	75 PSI
Min. Fluid Temp.	40°F
Max Fluid Temp.	140°F
Min. Ambient Temp	32°F
Max. Ambient Temp	104°F

Panel Info

Power Supply	1-230, 3-208-230/460/575
Enclosure	NEMA 12 (3R Available on Request)
Standard	Meets UL 508A
VFD's	Danfoss FC-51 /FC-101

PLC Info

User Interface	7" Color Touchscreen
Display Resolution	800 x 480 Pixels
Supply Voltage	24VDC
Max Current	320mA @24V
Analog Inputs/Outputs	9/2
Digital Inputs/Outputs	18/17
Communications	ModBUS Standard (BacNET, LONWorks Optional)
Ethernet Port	RJ45 (10/100Mbps)
Additional Ports	USB 2.0, Micro-SD

