

WILO-TS SERIES

Submersible Drainage Pumps



WILO-TS SERIES

Submersible Drainage Pumps

Product Features

- Durability and reliability due to impact-resistant stainless steel.
- Corrosion resistance for all wet parts.
- Space saving due to top discharge design.

Application

- Drainage for restaurant, spa, swimming pool, fountain.
- Drainage for construction site, agriculture, horticulture and flood control

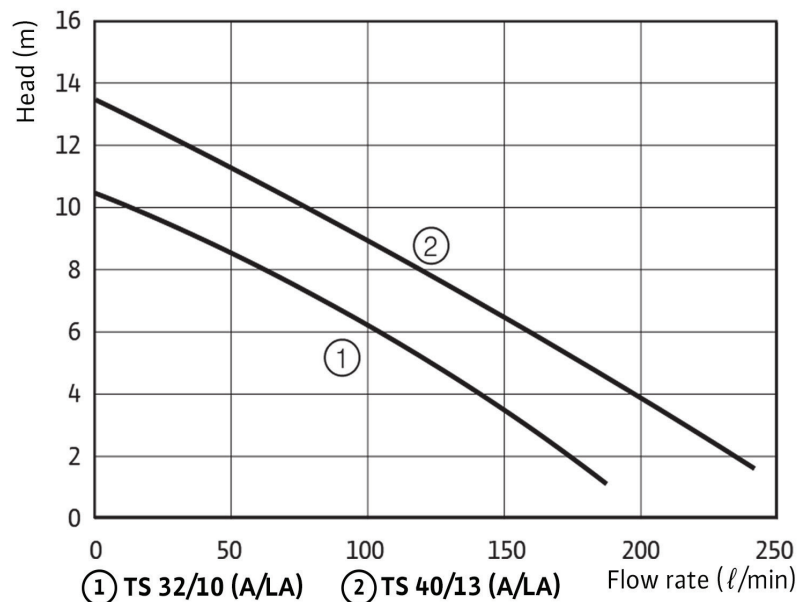
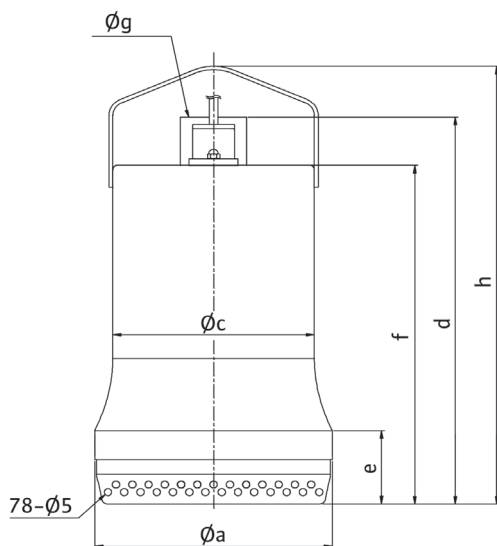

Model	Power Source	Output (W)	Discharge (mm)	Max. Head	Max. Flowrate (l/min)	Dimension						
						(ϕ)a	ϕ c	d	e	f	ϕ g	h
TS 32/10(A/LA)	Single Phase 220v 60hz	350	32(1 1/4")	10	175	161	136.5	280	53	246	32	317
TS 40/13 (A/LA)		600	40 (1 1/2")	13	220	171	146.5	304	77	269	40	344



WILO SE
 Representative Office (Philippines)
 Level 24, BGC Corporate Center
 30th St. Cor. 11th Ave.,
 Bonifacio Global City
 Taguig 1634, Philippines

T +632 8790 0178
 sales.ph@wilo.com
 www.wilo.ph

Stay connected with us!

