

**Wilo-Cronoline ICL
Inline Close-Coupled Pumps**

Installation and operating instructions

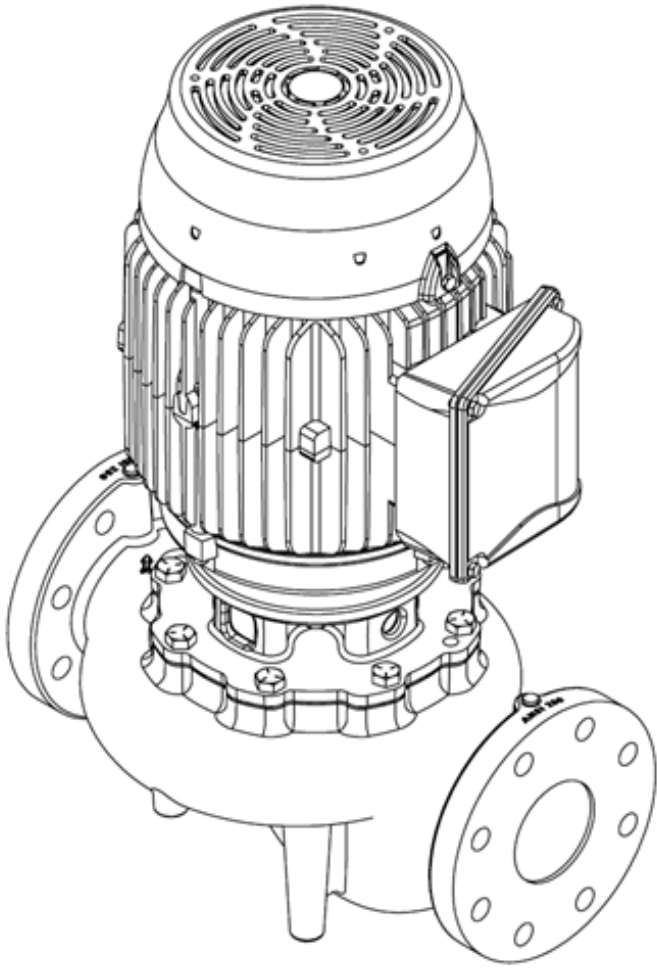

Contents

4" Series.....	3
6" and 8" Series.....	4
General.....	5
Safety.....	5
Technical Data.....	5
Functionality.....	6
Performance Regulation.....	6
Transport and Shipping.....	6
Mechanical Installation.....	7
Connect Condensate Drain.....	7
Electrical Connection.....	8
Fill and Ventilate.....	8
Check Direction of Rotation.....	9
Operation.....	9
Maintenance and Repair.....	9
Disassemble Pump.....	10
Assemble Pump.....	10
Screw Torques.....	11
Spare Parts.....	11
Troubleshooting Guide.....	12

4" Series

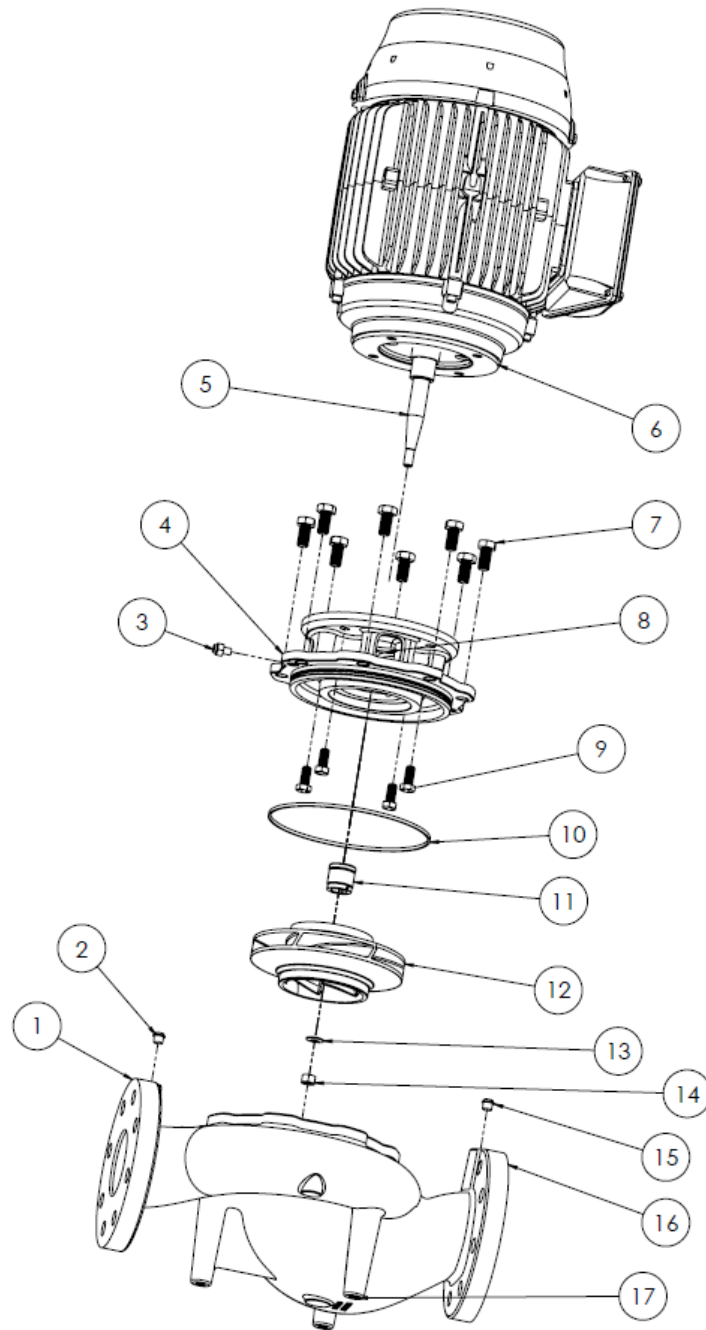

1. Discharge
2. Discharge Pressure Gauge Tapping – ¼" NPT
3. Air Vent – 1/8" NPT
4. Lantern
5. Shaft
6. Motor
7. Cover-plate Bolt
8. Condensate Drain Connection
9. Motor Frame Bolt

10. Lantern O-ring
11. Mechanical Seal
12. Impeller
13. Impeller Belleville Washer
14. Impeller Nut
15. Suction Pressure Gauge Tapping – ¼" NPT
16. Suction Inlet
17. Pump Mounting Feet

6" and 8" Series

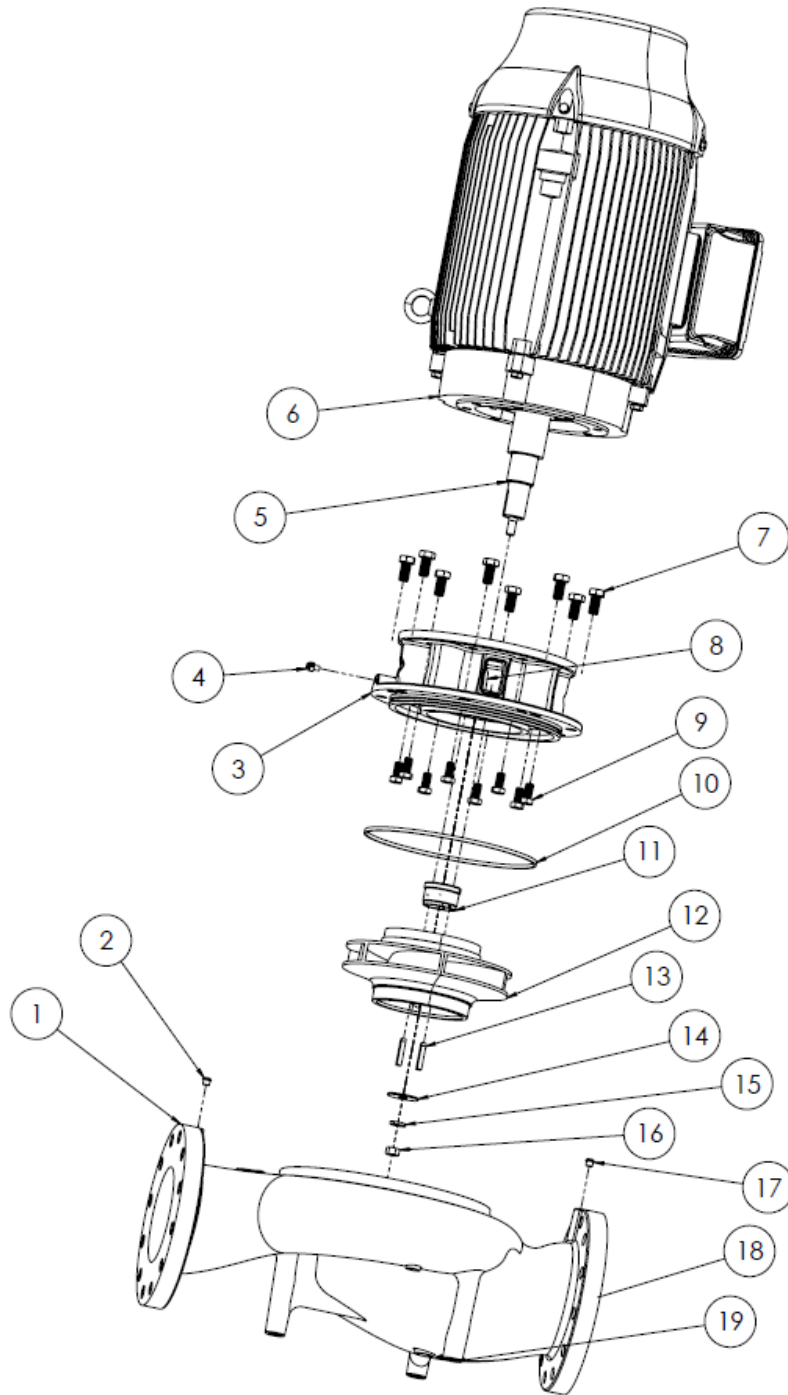

1. Discharge
2. Discharge Pressure Gauge Tapping – ¼" NPT
3. Lantern
4. Air Vent – 1/8" NPT
5. Shaft
6. Motor
7. Cover-plate Bolt
8. Condensate Drain Connection
9. Motor Frame Bolt
10. Lantern O-ring

11. Mechanical Seal
12. Impeller
13. Impeller Keys
14. Fender Washer
15. Split Lock Washer
16. Impeller Fastening Nut
17. Suction Pressure Gauge Tapping – ¼" NPT
18. Suction Inlet
19. Pump Mounting Feet

1. General

1.1 About these instructions:

These instructions must be read in full prior to installation. Failure to comply with these instructions may lead to serious injury or damage to the pump.





- i. Once the pump is installed, give these instructions to the operator.
- ii. These instructions should be kept in the vicinity of the pump. They serve as a reference in case of later problems.
- iii. Wilo is not liable for damage arising from non-compliance with these instructions.

2. Safety

2.1 These operating instructions contain basic information concerning the installation and commissioning of the system and should be read by the service technician and responsible operator prior to proceeding. Observe the special safety instructions and understand the danger symbols throughout this document.

2.1.1 Warning Notices:

Important safety notices are categorized as follows:

	Danger: Indicates life threatening due to electrical current.
	Warning: Indicates possible life threatening or risk of injury.
	Caution: Indicates possible threats to pump or other objects.
	Note: Highlights tips and information.

2.1.2 Safety Sticker:

Safety stickers giving important instructions on how to handle the pump are located on the motor. The instructions on the safety sticker must be strictly obeyed.

2.1.3 Qualifications:

The pump may only be installed by qualified personnel. The electrical systems may only be connected by qualified electricians. Additionally, national regulations concerning the qualifications of personnel must be obeyed.

2.1.4 Modification, Spare Parts:

No technical alterations or modifications may be made to the pump. Use only original spare parts.

2.1.5 Electrical Power Supply

Working with electrical current could cause serious risk of bodily injury, therefore:

- i. Before starting work on the pump, switch off the power and secure it against reconnection.
- ii. Do not bend or clamp power cable or expose it to heat sources.
- iii. Do not immerse the pump in water or other liquids or expose it to spray water or moisture.

2.1.6 Rotating Components

The pump contains rotating components that are exposed if the pump housing is open. Touching the rotating components can cause serious injury, therefore:

- i. Before opening the pump housing, switch off the motor and secure against reconnection.
- ii. Never switch on the motor when the pump housing is open.

2.1.7 High Deadweight

The pump has a very high deadweight, depending on the model. If the pump is dropped or it falls, there is a risk of death, therefore:

- i. Exercise caution when lifting or transporting.
- ii. Never walk under suspended loads.
- iii. Always put the pump and pump parts down ensuring they cannot tip over.
- iv. Only use the transportation methods described in these operating instructions L Page 6–7.
- v. Before loosening screws, secure the pump parts to prevent them from falling.

3. Technical Data

3.1 Type Key

Type Key	Example: ICL 4X4X8.86-TEFC-4-3-184TCZ-460-CI
Wilo Cronoline ICL	Series: Inline Pump ICL
4	Nominal Diameter of Suction End (inches)
4	Nominal Diameter of Discharge End (inches)
8.86	Impeller Diameter (inches)
TEFC	Totally Enclosed Fan Cooled
4	Number of Poles
3	Horse Power
184 TCZ	Motor Frame
460	Voltage
CI	Cast Iron
DI	Ductile Iron

Description	Information	Option
Mains voltage	460V	
Degree of motor protection	TEFC	
Protection against overheating	Integrated protection PTC / PTOa	•
Special motor design	Closed coupled motor shaft	
Max. working pressure	175 psi [12 bar] (CI) 363 psi [25 bar] (DI)	
Max. permissible liquid temperature range	-4 °F to 284 °F [-20 °C to +140 °C]	
Max. ambient temperature	104 °F [40 °C]	
Approved liquids	Heating water	
	Chilled/Cold water	
	Water/glycol mixtures b	
	Heat transfer oil (Viton seal only)	•
	Other liquids on request c	•

Legend: •Special design or accessories (at added cost on request)

- a. On-site trip unit required
- b. Hydraulic corrections necessary depending on liquid's density and viscosity. Only approved additives with corrosion inhibitors may be used. Observe manufacturer's instructions.
- c. Contact WIL0 before using any liquids other than above-listed liquids, different mixture ratios and higher temperatures.



Caution: Damage due to incorrect seal material

The pump must use a mechanical seal constructed with Viton elastomer if pump is moving oil. EPDM will shrivel in the presence of oil and will cause the mechanical seal to fail.



Note: For additional data, see type plate, product information sheet or Wilo catalog.

3.3 Materials

Pump housing and lantern	Cast Iron – Class 30 ASTM A48 Ductile Iron – ASTM A536
Impeller	Bronze – CC480K-GS
Pump shaft	Stainless Steel – AISI 420

3.4 Scope of Delivery

- i. Pump complete
- ii. Installation and operating instructions (not displayed) the NEMA standard.

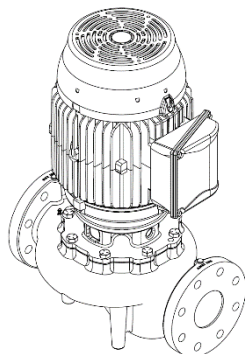

4. Functionality

4.1 Application

The purpose of the pump is to pump the liquids specified in the technical data for the building services industry and industrial plants. Pumping different liquids and exceed-ing the limit values specified in the technical data may destroy the pump.

4.2 Functions

4.2.1 Design:

The pump is a single-stage circulating pump with an inline design. It is driven by an electric motor according to the NEMA standard.

4.2.2 Performance Regulation:

External pressure sensors and an external control unit can be connected to the suction side and the discharge side by means of a pressure gauge tapping. The motor speed can be controlled using an external frequency converter.

4.2.3 Directions of Flow:

The arrow on the volute indicates the direction of flow.

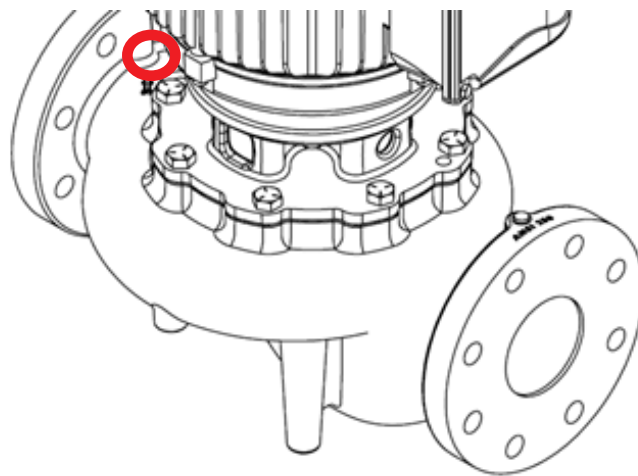

5. Transport and Shipping

5.1 Shipping

5.1.1 Shipping

The pump is delivered packaged in cardboard or lashed down on a pallet and is protected against dust and mois- ture.

5.1.2 Transport Inspection

Upon receipt, unpack and check pump and all accessories. Report transit damage immediately.

5.1.3 Storage

Until the pump is installed, the pump must be stored in a dry, frost-free place where it is also protected against mechanical damage.

⚠ Caution: Damage due to incorrect packaging!
If the pump needs to be transported again at a later date, it must be securely packaged for transit. Use the original packaging or equivalent packaging.

5.2 Impacts

⚠ Warning: Risk of injury due to high deadweight!
The pump is heavy and can cause considerable injury if dropped or if it falls. Only transport the pump using a suitable hoist. Wear work shoes and a helmet. Never stand under hanging loads.

To lift the pump using a crane, the pump has to be tied down as illustrated using suitable straps. Place the pump in the hanger which will tighten itself due to the pump's deadweight.

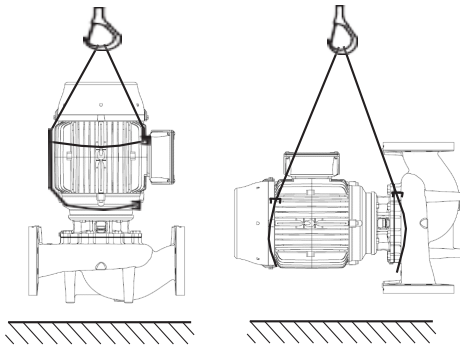

6. Installation

6.1 Mechanical Installation

⚠ Danger: Risk to life due to electric shock!
Before starting work, make sure that the pump is disconnected from the power supply.

⚠ Warning: Danger due to high deadweight!
The pump itself and pump components may have a very high deadweight. There is a risk of potentially fatal impact and crushing caused by falling parts. Always use suitable lifting equipment and secure parts from falling.

6.1.1 Installation Site

The installation site should be a weather-resistant, frost-free and dust-free area that has good air circulation. Select an easily accessible installation site. Keep a minimum distance of 8 inches [20 cm] between the motor cover and surrounding surfaces.

⚠ Caution: Dirt causes damage!
Dirt can render the pump inoperative. Before installing the pump, complete all welding and soldering work and thoroughly clean the pipe system.

i Note: Install an isolation valve (1) on the suction and discharge sides of the pump so that the pump can be replaced without having to empty the entire piping system.

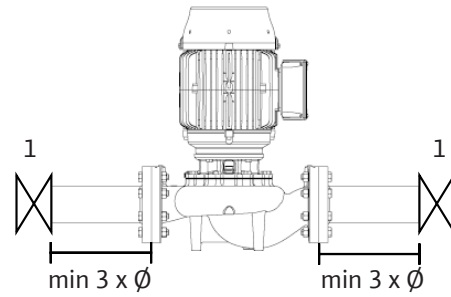

6.1.2 Attach Pump

2. Install only as shown (Figs. A/B):

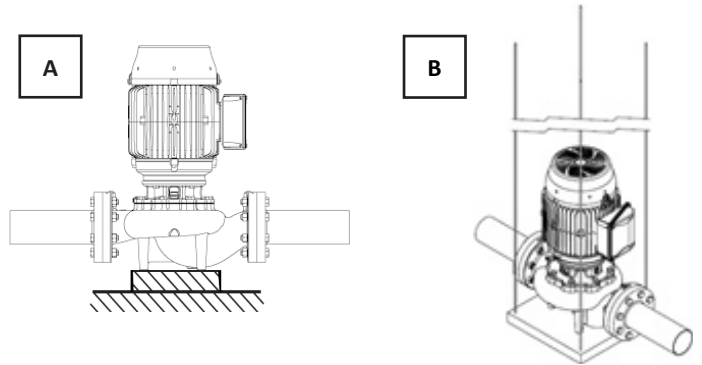

- 3. If necessary, disassemble the motor and rotate L Page 9.
- 4. The feet of the pump are drilled and tapped for floor mounting (A). Insure the volute is not stressed by the piping.

⚠ Caution: Damage due to improperly secured pump!
For ceiling mounted pumps, motor must be secured to a suspended base to avoid damage to the pump and surrounding areas (B). Excessive vibration or other disturbances may cause unsecured pump to rotate about the pipe connections (C). Base not provided.

5. **DO NOT** connect pump to piping using pipe supports.

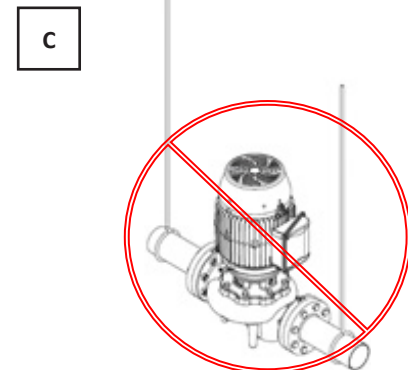

⚠ Danger: Risk to severe damage or injury!
Support the pump with drilled feet or sitting on a secure pedestal. Pump can freely float with ANSI flanged connections.

6. If desired, a condensate drain can be connected.
(2) Condensate drain for vertical installation position of the motor
7. Seal up unused condensate drain.

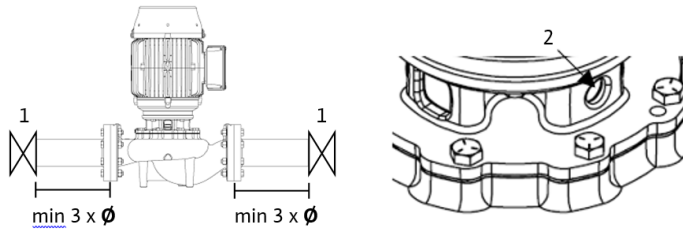

⚠ Caution: Damage due to overheating!
For insulated piping systems, only the pump volute may be insulated, not the lantern and the motor. These could be damaged by heat build-up.

7. Electrical Connection

⚠ Danger: Life threatening due to electrical shock!
Touching live parts can be fatal. Work on the electrical connection may only be performed by a trained electrician. Prior to connecting, ensure that the connecting line is voltage-free.

⚠ Warning: Danger due to a damaged cable!
For pumps that pump hot liquids or that are used in proximity to hot surfaces with temperatures above 194°F [90°C], a heat-resistant cable must be used.

i Note: For the correct cable size, refer to local wiring restrictions.

7.1 Electrical Connection

1. Connect the connecting cable with power switched off and secure against reconnection.
2. Lay the connecting cable such that it doesn't come into contact with the pump, the pump housing, or the piping.
3. Check whether the voltage and amperage in the mains match the specifications on the type plate of the pump.

⚠ Caution: Damage due to incorrect voltage!
Never operate the pump with incorrect voltage. This could damage the motor.

4. Open the terminal box.
5. Lay the cable such that no condensation or spray water can make contact with the cable screws (Fig. A).

6. Connect grounding cable.
7. Install motor control, cabling, overload protection, mains circuit breaker and accessories in accordance with the locally applicable safety regulations.

i Note: The connection diagram is located on an exterior label or inside the terminal box.

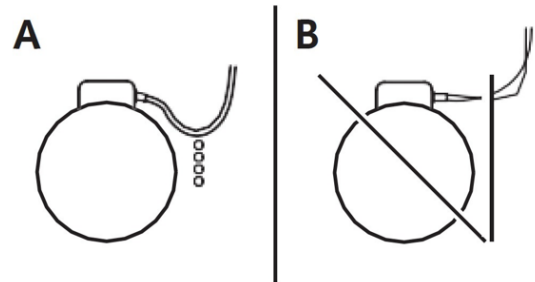

i Note: Special motors can be supplied with a PTC thermal sensor that must be connected to the PTC trip relay.

8. To protect the motor, overheating protection should also be installed.
9. Tighten cable screws
10. Close terminal box and ensure that no spraying water can enter it.
11. Low temperature applications (below normal temperature range) can be used with Glycol up to a 50% concentration.

7.1.1 Caution when connecting to an automatic pump control device

Comply with respective installation and operating instructions when wiring to automatic pump control device (DDC or Building Management Systems). Be sure the following guidelines are met:

*AC power is within $\pm 10\%$ of rated voltage with rated frequency (see motor name plate for ratings)

or

*AC power is within $\pm 5\%$ of rated frequency with rated voltage

or

*Combined variation in voltage and frequency of $\pm 10\%$ (sum of absolute values) of rated values, provided the frequency variation does not exceed $\pm 5\%$ of rated frequency

8. Fill and Ventilate

8.1 Ventilate



Caution: Damage due to overheating!

For insulated piping systems, only the pump volute may be insulated, not the lantern and the motor. These could be damaged by heat build-up.



Warning: Danger due to hot liquid under pressure!

Extreme caution must be used when venting systems that have elevated temperatures and/or dangerous fluids. Maintain sufficient distance from the air vent opening. Wear suitable clothing including protective glasses/facial protection and gloves.



Caution: Damage due to cavitation!

Failing to maintain minimum pressure on the suction side can lead to cavitation accompanied by noise. This can damage the pump. This minimum inlet pressure depends on the operating conditions and the duty point of the pump and must be calculated accordingly. Please contact WILO or your WILO distributor if this information is required.

1. Open air vent valve (1) 1/2 turn, do not remove.
2. Completely open suction side and discharge side isolation valves.
3. Wait until the liquid has exited the ventilation opening and until bubbles no longer form.
4. Tightly close the ventilation opening.

8.2 Avoid Cavitation

5. Ensure that the minimum pressure stipulated in the product catalog is present on the suction side.

8.3 Check Direction of Rotation

6. Check the motor's direction of rotation by briefly turning it on. The direction of rotation is correct if the fan or other visibly rotating parts of the pump are rotating in the direction of the arrow (2).
* On three phase only, if the direction of rotation is incorrect, have an electrician correct it by swapping two phases.
7. Turn on the pump for test operation and observe whether it is pumping correctly. If necessary, ventilate again until a sufficient pumping result is achieved.

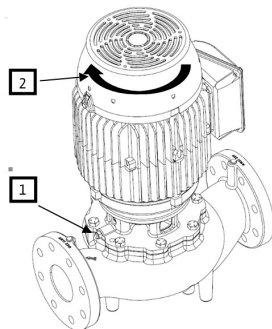

9. Operation



Warning: Risk of burning or freezing if the pump is touched!

Depending on the operating conditions of the pump or installation (liquid temperature), the entire pump can become very hot or very cold. Keep your distance during pump operation!



Caution: Damage due to overheating!

The pump may not be operated longer than 1 minute without flow. An accumulation of energy creates heat that can damage the pump shaft, impeller and mechanical seal. A minimum flow rate of approx. 10% of maximum flow rate must always be guaranteed.

10. Maintenance and Repair



Danger: Life threatening due to electrical shock!

Touching live components can be fatal. Only qualified electricians may work on the electrical system. Prior to any maintenance work, disconnect the pump from the power supply and secure against reconnection.



Warning: Damage due to incorrectly tightened screws!

Overtightened screws can break off. Subsequently, separate parts and fragments may chip off and /or the hot liquid may spray. Observe screw tightening torque specifications L Page 11



Warning: Danger due to hot liquid under pressure!

During dismantling of motor or pump, hot liquids may escape under high pressure. Allow the pump to cool down first. Close isolation valve prior to dismantling pump.



Caution: Damage due to incorrectly performed maintenance!

Incorrectly performed maintenance work can damage the pump. The maintenance work described below may therefore only be performed by trained personnel.

Cleaning

- 10.1 Clean the exterior of the pump using only a lightly damp-ened cloth without detergents.

Checks

- 10.2 Under normal operating conditions, the pump does not require regular maintenance work. The following points, however, must be checked at regular intervals.

Check	Solution
Leakages	If the leakage rate increases (> 5 ml/h [0.2 oz/hr]), replace the mechanical seal L Page 10
Motor noise and vibrations	-Check whether the pump is being operated within the permitted characteristic curve range (see product catalog).
	If level of noise increases due to motor mounting or increased vibrations, replace motor L Page 10, or replace the motor mounting (see instructions from motor manufacturer).

10.3 Disassemble Pump

10.3.1 Dismantle Lantern from Volute

1. Disconnect pump from power supply and secure against reconnection.
2. Close shut-off device in front and rear of pump.
3. If the connection cable is too short for disassembly, have an electrician disconnect it.
4. Remove all other connections (e.g. condensate drain).
5. Remove bolts on lantern flange connecting the lantern and volute.
6. Screw bolts into threaded extraction holes next to drill holes on lantern flange in order to press lantern out from pump housing.
7. Take out pump assembly with motor, mechanical seal, and impeller using suitable lifting equipment and remove from pump housing.

10.3.2 Remove Impeller

8. Loosen impeller fastening nut counter-clockwise.
9. Loosen impeller from pump shaft using an extractor. In doing so, place extractor hook under impeller near blade.
10. Remove nut, washer, and impeller from shaft. For 6" and 8" series, also remove keys.

10.3.3 Remove Seal

11. For pumps with DI volute, loosen setscrews on mechanical seal.
12. Remove mechanical seal from shaft.
13. Using suitable lifting equipment, secure lantern, and then remove the screws on motor flange
14. Pull lantern from motor and set on flat surface
15. Remove O-ring from lantern.

10.4 Assemble Pump

1. Carefully clean seal locations. They must not be damaged.
2. Check machined surfaces and clean if necessary

3. With motor on suitable lifting equipment, align and place lantern with the motor.
4. Insert and tighten screws connecting lantern to motor.
5. Tighten all screws on motor flange using torquewrench. Torque L Page 11.
6. Press new mechanical seal onto the shaft and into the lantern. Use a small amount of approved polymer lubricant and press stationary section of seal into lantern with two thumbs. Also lubricate O-ring of rotating section of the seal to allow for easy installation. For pumps using CI volutes this is all that is required. Continue to step 15. For pumps using DI volutes, complete steps 7-14.



Caution: Damage to seal due to improper lubrication!

Be sure not to use too much lubricant on the stationary section of the seal as this may allow the seal to slide back out. To ensure proper contact and extend the life of the seal, make sure the seal faces remain clean and free of lubricant.

7. Choose two unthreaded holes on lantern face that are across from each other.
8. Rotate mechanical seal so one of the three set screws on the seal is perpendicular to the line that would connect the two selected unthreaded holes.
9. Slide application tool with feet facing the lantern face over the motor shaft and align threaded holes of with unthreaded holes on lantern face.
10. Make sure the flat side of the tool is perpendicular to selected setscrew. The other two setscrews should be visible in two notches on opposite side of application tool.
11. Take two bolts meant to fasten lantern to the volute. Insert them through back of lantern and tighten until tool makes contact with lantern surface. This compresses seal to working height.
12. Use a hex key to tighten each setscrew. Torque L Page 11.
13. If tool overhangs seal, locate setscrew under the overhang before tightening.
14. When setscrews are firmly tight, remove both bolts from tool and slide off shaft.
15. Insert a new O-ring in lantern groove.
16. Place impeller onto shaft.
17. For 6" and 8" series, line-up impeller key slots with shaft key slots and insert keys.
18. Slide on washer then screw on impeller fastening nut.
19. Screw nut tightly using a torque wrench. Torque L Page 11.
20. Insert current assembly carefully into pump housing using suitable lifting equipment. Tighten screws on lantern flange using a torque wrench. Torque L Page 11.

21. Prior to turning on the power, check whether shaft unit is easy to rotate and does not grind. If necessary, dismantle components again, check fits, and repeat assembly process.



Caution: Damage to the pump!

Never operate a pump that is not correctly assembled. This can damage the pump.

10.5 Screw Torques

Location Material/SAE Grade	Diameter (inches)	Torque ($\pm 10\%$)	
		ft lb	Nm
Impeller-Shaft Stainless steel	3/8	22	30
	1/2	44	60
	5/8	74	100
Pump housing - lantern SAE Grade 5	5/8	75	100
Adapter flange - lantern SAE Grade 5	5/16	18	25
	1/2	44	60
Lantern - motor SAE Grade 5	3/8	26	35
	1/2	44	60
	5/8	74	100
Pressure taps - plug screw	1/4-18 NPT	15	20
Mechanical Seal	M4	1.4	1.85
	M5	2.7	3.6

11. Spare Parts

In order to avoid returns and incorrect orders, please specify the name plate data for all orders.

Caution: Damage to incorrect spare parts!

Only original Wilo spare parts are to be used to insure fault-free pump operation

12. Troubleshooting Guide

Faults	Possible Cause	Remedy
Pump does not start or fails to run	Pump Seized	Switch off power supply, take off pump head, remove obstruction; if motor blocked, overhaul/exchange motor/pump head
	Loose Terminals	Tighten all terminals
	Blown fuses/breakers	Check fuses, replace/reset as necessary
	Faulty motor	Call service
	Tripped overload relay (excessive amp draw)	Throttle hydraulic flow rate down to nominal on discharge side of pump
	Incorrectly set trip relay (heaters)	Reset thermal overloads to full load current value specified on name plate
	Thermal overload is influenced by excessive ambient temperature	Prevent overloads caused by high ambient temperatures
	Tripped PTC relay	Check motor and fan cover for dirt/dust accumulation and clean if necessary; Check ambient temperature and if necessary, ensure an ambient temperature $\leq 105^{\circ}\text{F}$ [40°C] by forced ventilation.
Pump runs at reduced capacity	Incorrect rotation	Check direction of rotation, reverse if necessary
	Discharge valve throttled too far	Slowly open isolating valve
	Speed too low	Adjust incorrect terminal bridging (Y in lieu D)
	Air in suction pipe	Check and correct all possible suction leaks
	Insufficient inlet pressure	Raise inlet pressure, ensure minimum required inlet pressure at suction port, check and if necessary clean suction-side isolating valve and strainer
Pump makes noise	Faulty motor bearings	Arrange for pump to be inspected and, if necessary, to be repaired by Wilo or other authorized service.



Note: If you cannot fix the problem, contact service engineer or a Wilo branch office.

WILO USA LLC

+1 888-945-6872
www.wilo-usa.com
info@wilo-usa.com

Wilo Canada Inc.

+1 866-945-6236
www.wilo-canada.com
info@wilo-canada.com

Wilo Mexico

+52 442 167 00 32
www.wilo-mexico.com
info@wilo.com.mx

wilo®