

Submittal Data Sheet

Wilo SCP – Horizontal Split Case Pumps

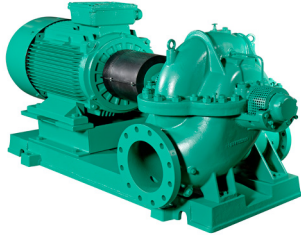

SCP 14 x 12 x 19 HA



Project:										
Engineer:										
Contractor:										
Submitted By:					Date:					
Approved By:					Date:					

Tag #	Model #	Flow (USGPM)	Head (Feet)	HP	Enclosure TEFC/ODP	Frame	Cycle	Phase	Voltage	RPM
	SCP 14 x 12 x 19 HA						60 Hz	3		

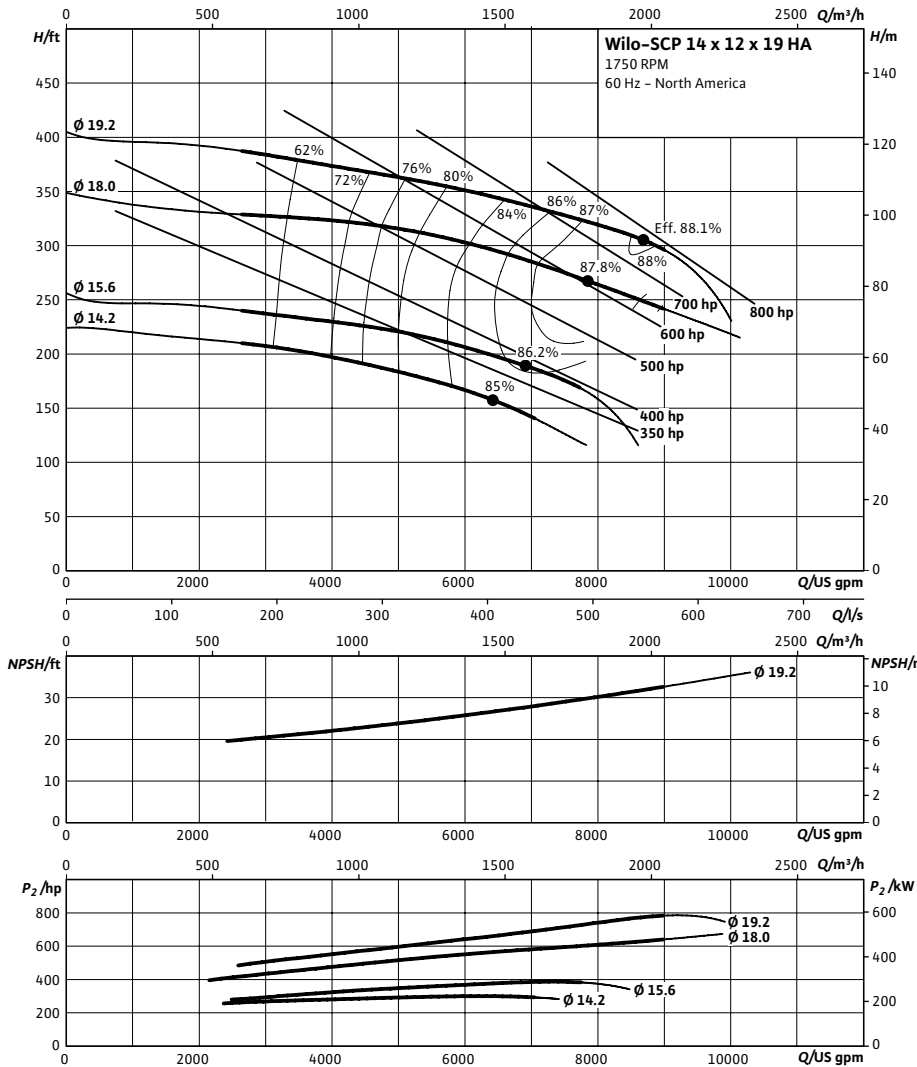

Technical Data

Approved Fluids

Heating Water
Cooling and cold water

Water-Glycol mixtures (for 20-40% glycol and fluid temp ≤ 104°F [40°C])

Fluid Temperature

Mechanical Seal 18°F to 250°F (-8°C to 120°C)
Stuffing Box Packing 18°F to 220°F (-8°C to 105°C)

Materials of Construction

<input type="checkbox"/>	Pump Housing	A48 Class 35
<input type="checkbox"/>	Pump Housing (Optional)	Ni-resist BS 3468 Gr 2 / BS 2789 500.1
<input type="checkbox"/>	Impeller	BS 84 C83 600
<input type="checkbox"/>	Impeller (optional)	A48 Class 35 / BS 84 C83 600
<input type="checkbox"/>	Stationary Wear Rings	BS 84 C93 700
<input type="checkbox"/>	Pump Shaft	A276 type 410
<input type="checkbox"/>	Pump Shaft (optional)	BS 970 316 S16
<input type="checkbox"/>	Mechanical Seal	Carbon/silicon carbide/EPDM (E1)
<input type="checkbox"/>	Other Mechanical Seals	Avail. on request
<input type="checkbox"/>	Additional Spacer Coupling	Avail. on request
<input type="checkbox"/>	Other:	

Approval Stamp

Dimensional Drawing

Single Stage Pump

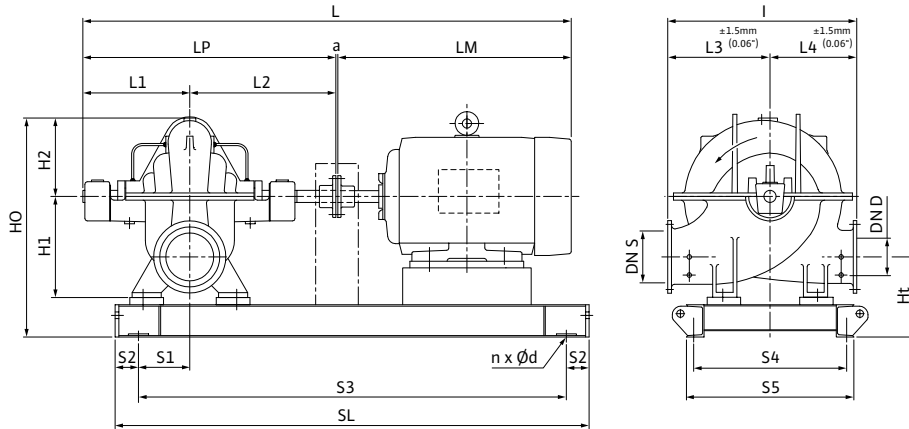

SCP 14 x 12 x 19 HA

Dimensions - Inches (mm)

Frame	a	L	I	L1	L2	L3	L4	LM	LP	H1	H2	HO	Ht	n	Ød	S1	S2	S3	S4	S5	SL	P5	P6
449T/ 350 hp	.19 (5)	104.25 (2678)	42.00 (1067)	23.38 (594)	27.31 (694)	23.00 (584)	19.00 (483)	53.38 (1356)	50.69 (1284)	23.25 (591)	15.94 (405)	46.13 (1172)	16.69 (424)	4	.91 (23)	10.75 (273)	4.00 (102)	79.50 (2019)	23.63 (600)	26.38 (670)	87.50 (2223)	-	-
449T/ 400 hp	.19 (5)	104.25 (2678)	42.00 (1067)	23.38 (594)	27.31 (694)	23.00 (584)	19.00 (483)	53.38 (1356)	50.69 (1284)	23.25 (591)	15.94 (405)	46.13 (1172)	16.69 (424)	4	.91 (23)	10.75 (273)	4.00 (102)	79.50 (2019)	23.63 (600)	26.38 (670)	87.50 (2223)	-	-

Flange Dimensions - Suction Side

Dimensions - Inches (mm)

DN S #125	ØD	Ød	Øk	b	n	D2
14	21.00 (533)	16.25 (413)	18.75 (476)	1.38 (35)	12	1.13 (29)

Flange Dimensions - Discharge Side

Dimensions - Inches (mm)

DND 125#	ØD	Ød	Øk	b	n	D2
12	19 (483)	15.00 (381)	17.00 (432)	1.25 (32)	12	1.00 (25)

