

Submittal Data Sheet

Wilo SCP – Horizontal Split Case Pumps

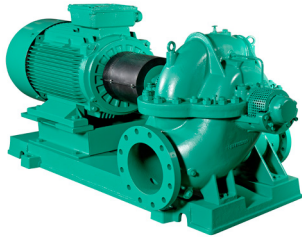

SCP 10 x 8 x 22 HA



Project:	
Engineer:	
Contractor:	
Submitted By:	Date:
Approved By:	Date:

Tag #	Model #	Flow (USGPM)	Head (Feet)	HP	Enclosure TEFC/ODP	Frame	Cycle	Phase	Voltage	RPM
	SCP 10 x 8 x 22 HA						60 Hz	3		

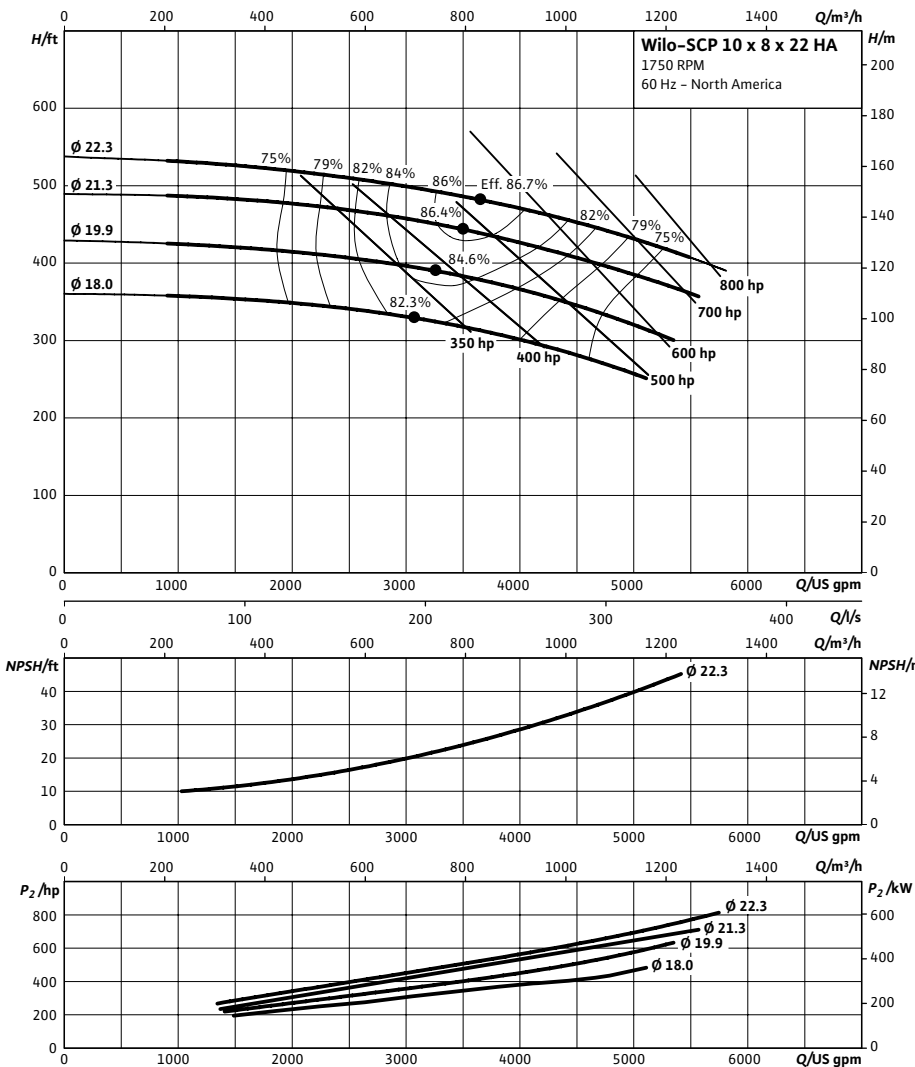

Technical Data

Approved Fluids
 Heating Water
 Cooling and cold water
 Water-Glycol mixtures (for 20–40% glycol and fluid temp ≤ 104°F [40°C])

Fluid Temperature
 Mechanical Seal: 18°F to 250°F (-8°C to 120°C)
 Stuffing Box Packing: 18°F to 220°F (-8°C to 105°C)

Materials of Construction

<input type="checkbox"/> Pump Housing	A48 Class 35
<input type="checkbox"/> Pump Housing (Optional)	Ni-resist BS 3468 Gr 2 / BS 2789 500.1
<input type="checkbox"/> Impeller	BS 84 C83 600
<input type="checkbox"/> Impeller (optional)	A48 Class 35 / BS 84 C83 600
<input type="checkbox"/> Stationary Wear Rings	BS 84 C93 700
<input type="checkbox"/> Pump Shaft	A276 type 410
<input type="checkbox"/> Pump Shaft (optional)	BS 970 316 S16
<input type="checkbox"/> Mechanical Seal	Carbon/silicon carbide/EPDM (E1)
<input type="checkbox"/> Other Mechanical Seals	Avail. on request
<input type="checkbox"/> Additional Spacer Coupling	Avail. on request
<input type="checkbox"/> Other:	

Approval Stamp

Dimensional Drawing

Single Stage Pump

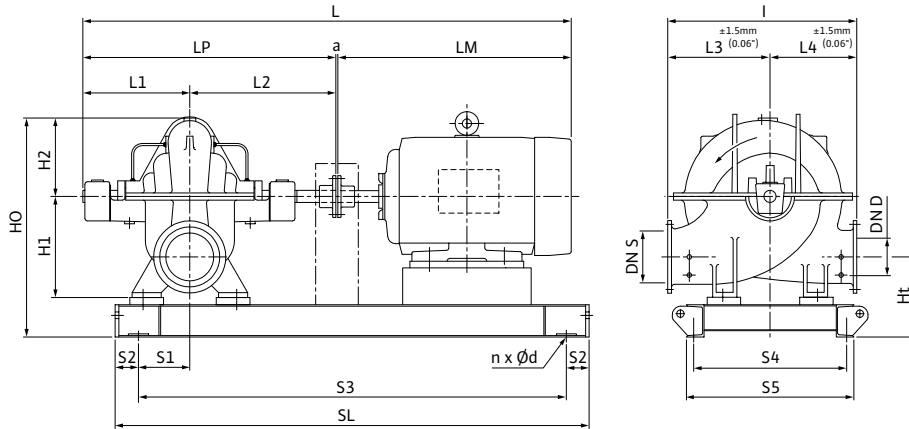

SCP 10 x 8 x 22 HA

Dimensions - Inches (mm)

Frame	a	L	I	L1	L2	L3	L4	LM	LP	H1	H2	HO	Ht	n	Ød	S1	S2	S3	S4	S5	SL	P5	P6
449T / 350 hp	.19 (5)	104.25 (2648)	38.56 (979)	23.38 (954)	27.31 (694)	20.50 (521)	18.06 (459)	23.38 (1356)	20.69 (1288)	21.50 (546)	15.56 (395)	44.00 (1118)	14.44 (367)	4	.91 (23)	9.75 (248)	4.00 (102)	78.50 (1994)	23.63 (600)	26.38 (670)	86.50 (2197)	-	-
449T / 400 hp	.19 (5)	104.25 (2648)	38.56 (979)	23.38 (954)	27.31 (694)	20.50 (521)	18.06 (459)	23.38 (1356)	20.69 (1288)	21.50 (546)	15.56 (395)	44.00 (1118)	14.44 (367)	4	.91 (23)	9.75 (248)	4.00 (102)	78.50 (1994)	23.63 (600)	26.38 (670)	86.50 (2197)	-	-

Flange Dimensions – Suction Side

Dimensions - Inches (mm)

DN S #125	ØD	Ød	Øk	b	n	D2
10	16.00 (406)	12.75 (324)	14.25 (362)	1.19 (30)	12	1.00 (25)

Flange Dimensions – Discharge Side

Dimensions - Inches (mm)

DN D 125#	ØD	Ød	Øk	b	n	D2
8	13.50 (343)	10.63 (270)	11.75 (298)	1.13 (29)	8	.88 (22)

