

**wilo**®



## Wilo IL Vertical Split-Coupled Inline Pumps

**Vertical Inline Split-Coupled, Single Stage Pumps – March, 2013**

Marcos D. Roimicher, Product Manager BS Market Segment, Product Management Department

---

## Agenda

1. Features and Benefits
2. General Technical Specifications
3. Model Number Designation
4. Family Curves
5. Detailed Technical Features / Construction Details / Features and Benefits
6. Installation Instructions
7. Ordering Information

---

## Features and Benefits

### **WILO Brain “Easy Read” Model Numbering System**

- References flange size and performance in standard North American units

### **Uses Baldor NEMA “C” Frame Motors (other Manufacturer’s are OK)**

- All voltages and enclosures available
- Various efficiency types and VFD-ready
- Do not need to be Inverter Duty

### **Excellent Delivery Times – 72 hours**

- Common pump ends and motors stocked in Thomasville, Georgia

## Features and Benefits

### **¼" Pressure Gauge Tappings Standard**

- Suction and discharge
- Using square headed threaded plugs

### **Excellent Commercial Pump Warranty**

- 24 months from date of purchase

### **German Designed and Built specifically for the North American Market**

- Heavy duty design – extremely robust!

---

## General Technical Specifications

### Size Range – Flange Size

- 1-¼" to 4"
- 46 Models @ 2 Pole (3600 RPM)
- 53 Models @ 4 Pole (1800 RPM)

### Horsepower Range

- 2 Pole (3600 RPM) - 1.0 to 60 Hp
- 4 Pole (1800 RPM) - 0.5 to 30 Hp

### Performance

- 2 Pole (3600 RPM), flows to 1600 US GPM, heads to 200' TDH
- 4 Pole (1800 RPM), flows to 430 US GPM, heads to 65' TDH

---

## General Technical Specifications

### Standard Construction Material Specification

- Cast iron, bronze fitted
- Standard and custom impeller trims (trimmed and tested in Thomasville, GA)
- All cast iron version available (optional)
- Inlet straightening vanes on models 3" and 4"

### All models are ANSI Flanged

- 125 PSI raised face ANSI flanges
- High pressure volute (300 PSI rating, all models)

### Standard Mechanical Seal

- Both water and water-glycol mixtures to + 230°F (+ 110°C)
- 285°F (141°C) rating available (special seal)

### Noise and Vibration Levels to Hydronic Institute Standards

## Model Number Designation

IL 2.5 50/260 - 2

**IL**

- Inline Vertical Split-Coupled Pump, Single Suction, Dry Rotor, "Mechanical sealed"
- Bronze fitted flanged type

### 2.5 Suction and Discharge Size in Inches

- 125# ANSI raised face standard (150# same as 125#)
- 250# ANSI raised face optional (300# same as 250#)

### 50 Maximum Pumping Head in Feet

### 260 Maximum Flow in US GPM

### 2 # of Poles

- 2 poles = 3450 RPM, 4 poles = 1750 RPM

Note: Complete units include motor HP, motor enclosure, HP, # poles (RPM), frame size, phase and voltage

## Family Curves – 4 Pole, 1750 RPM Models, 60 Hz, Post-March 2013

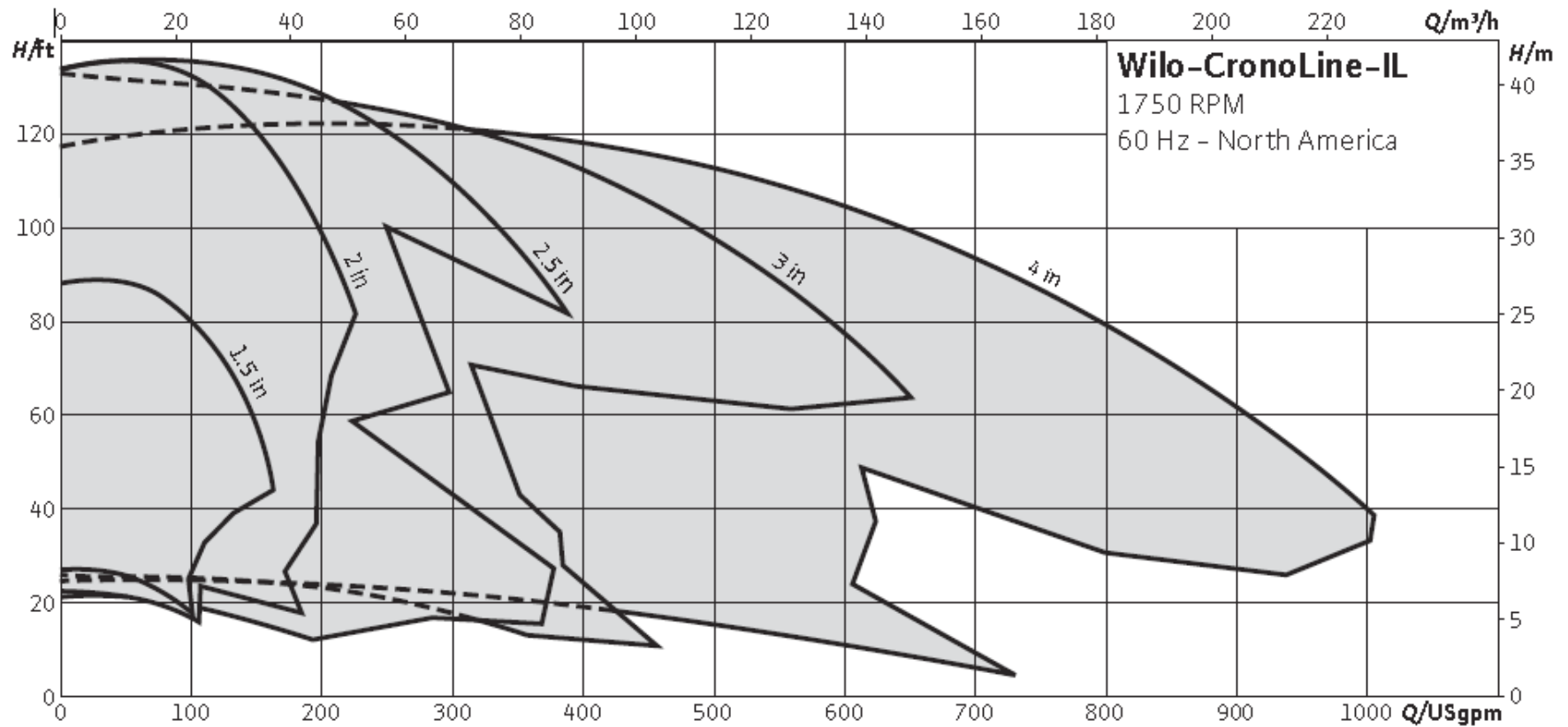



## Family Curves – 4 Pole, 1750 RPM Models, 60 Hz, Pre-March 2013

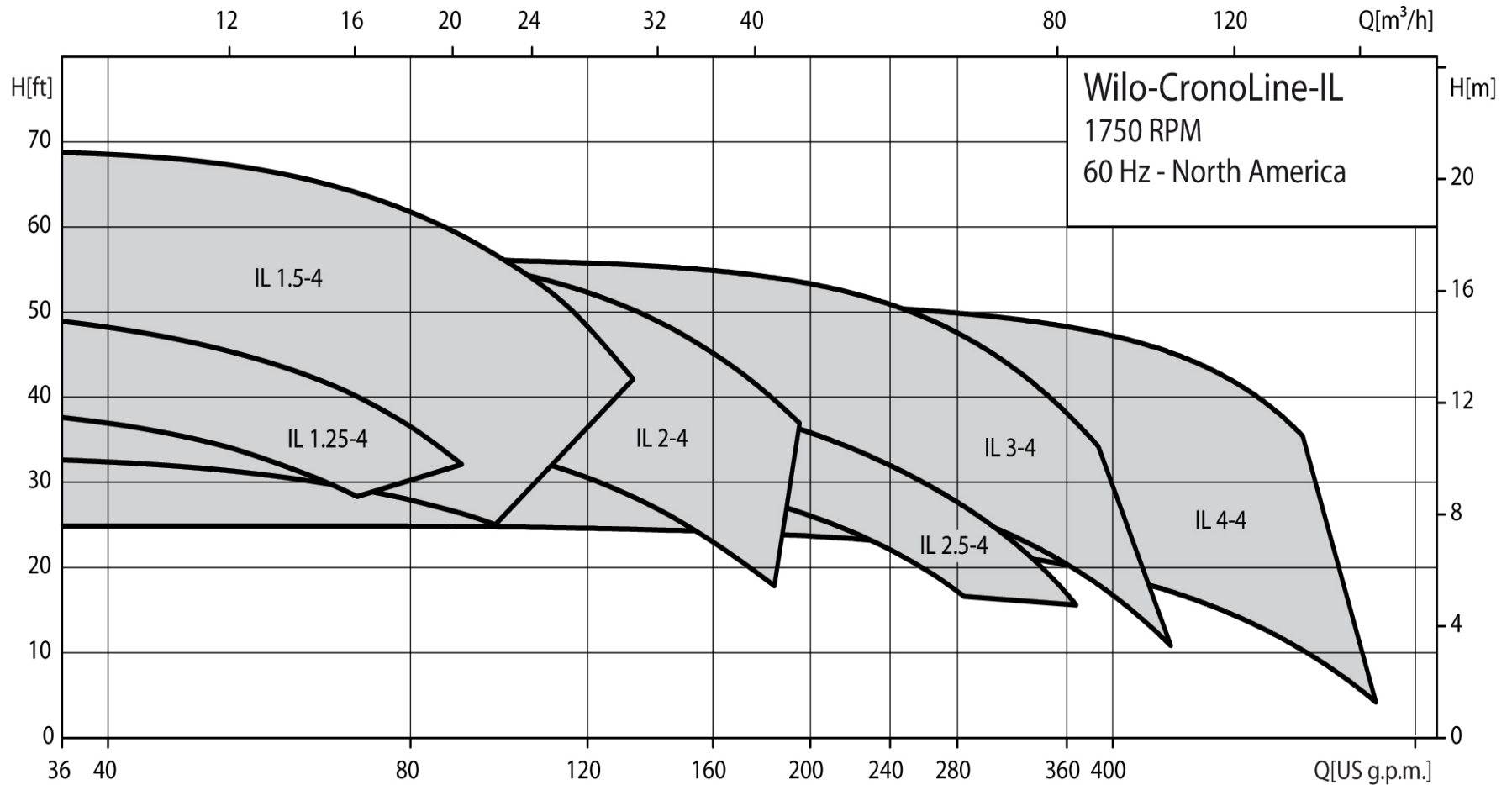

## Family Curves – 2 Pole, 3500 RPM Models, 60 Hz, Post-March 2013

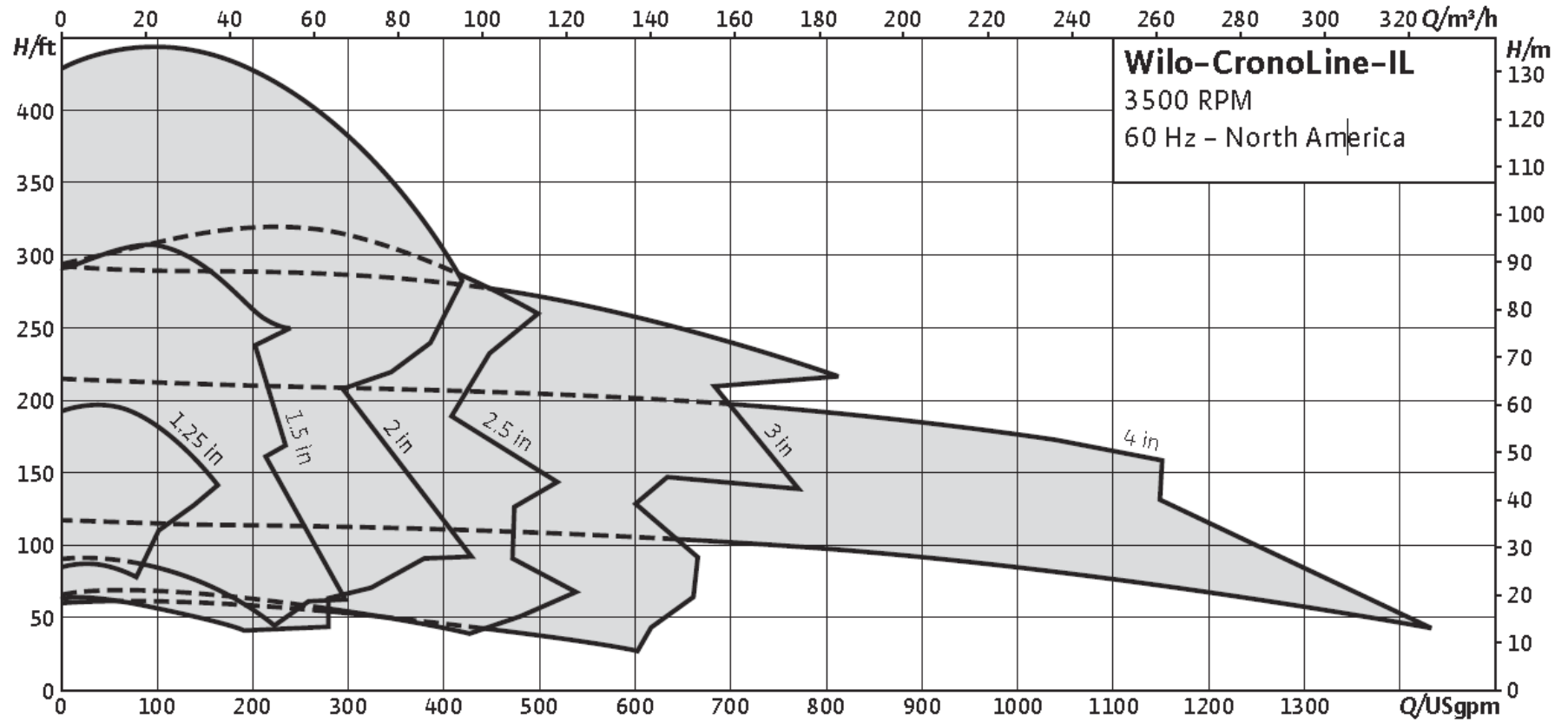

# Family Curves – 2 Pole, 3500 RPM Models, 60 Hz, Pre-March 2013

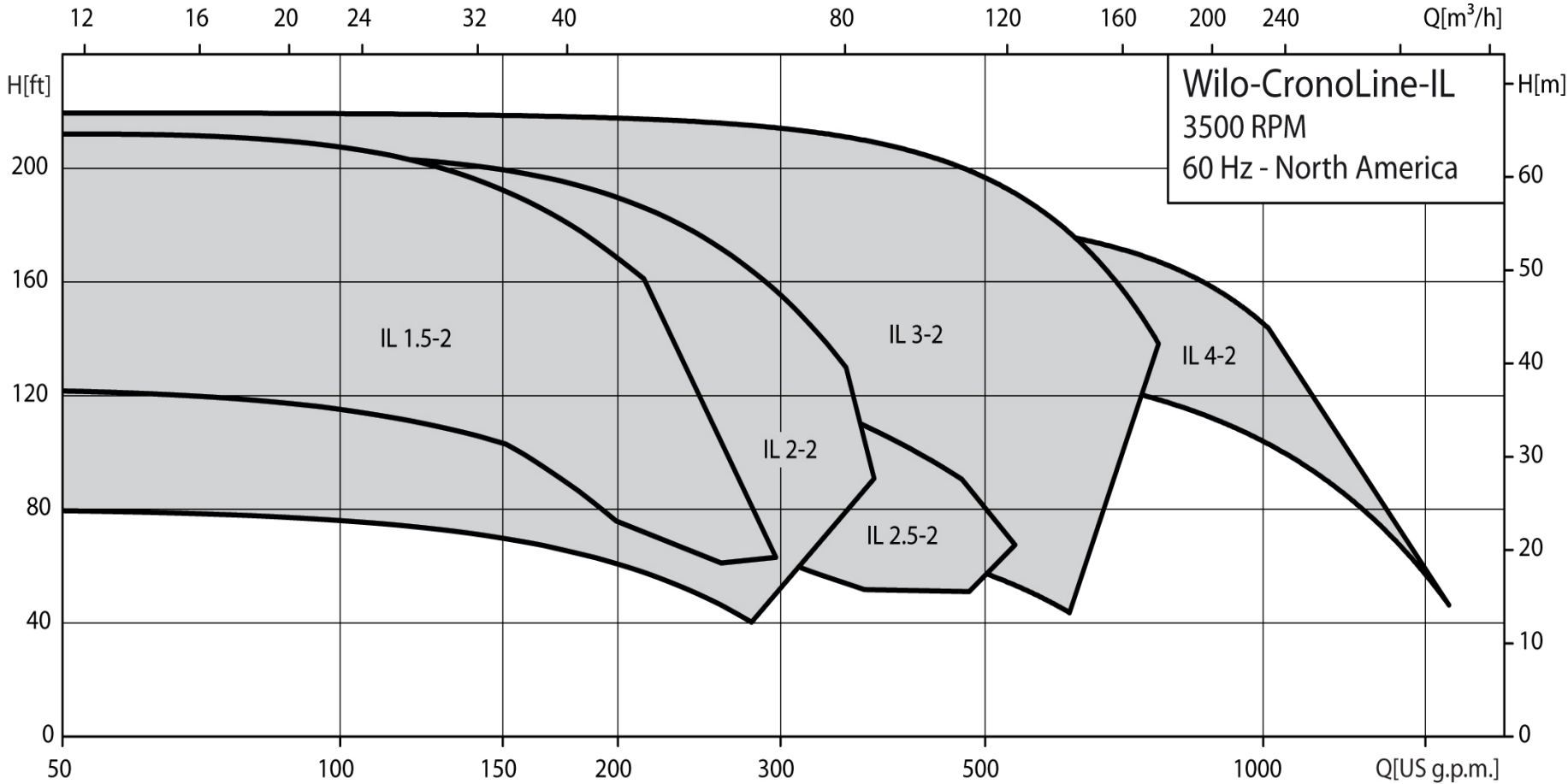

---

## Detailed Technical Features

### Painting

- 2-part epoxy paint as per internal standards
- Primer: Red Oxide Zinc Coated ~ 40 microns thick
- Final top coat: Enamel paint ~ 40 microns thick - "Wilo green" (Pantone 334) as standard
- Customized paint available upon request, will require longer lead time and extra cost

### Construction Features

- Electrophoretical coating inside of the pump body and lantern
- Pressure rating (standard construction) 150 PSI with 1.5 times the hydrostatic test pressure (Hydraulic Institute Standard)
- (2) Eye bolts for lifting
- Oversized radial ball bearings in the vertical motors

## Detailed Technical Features

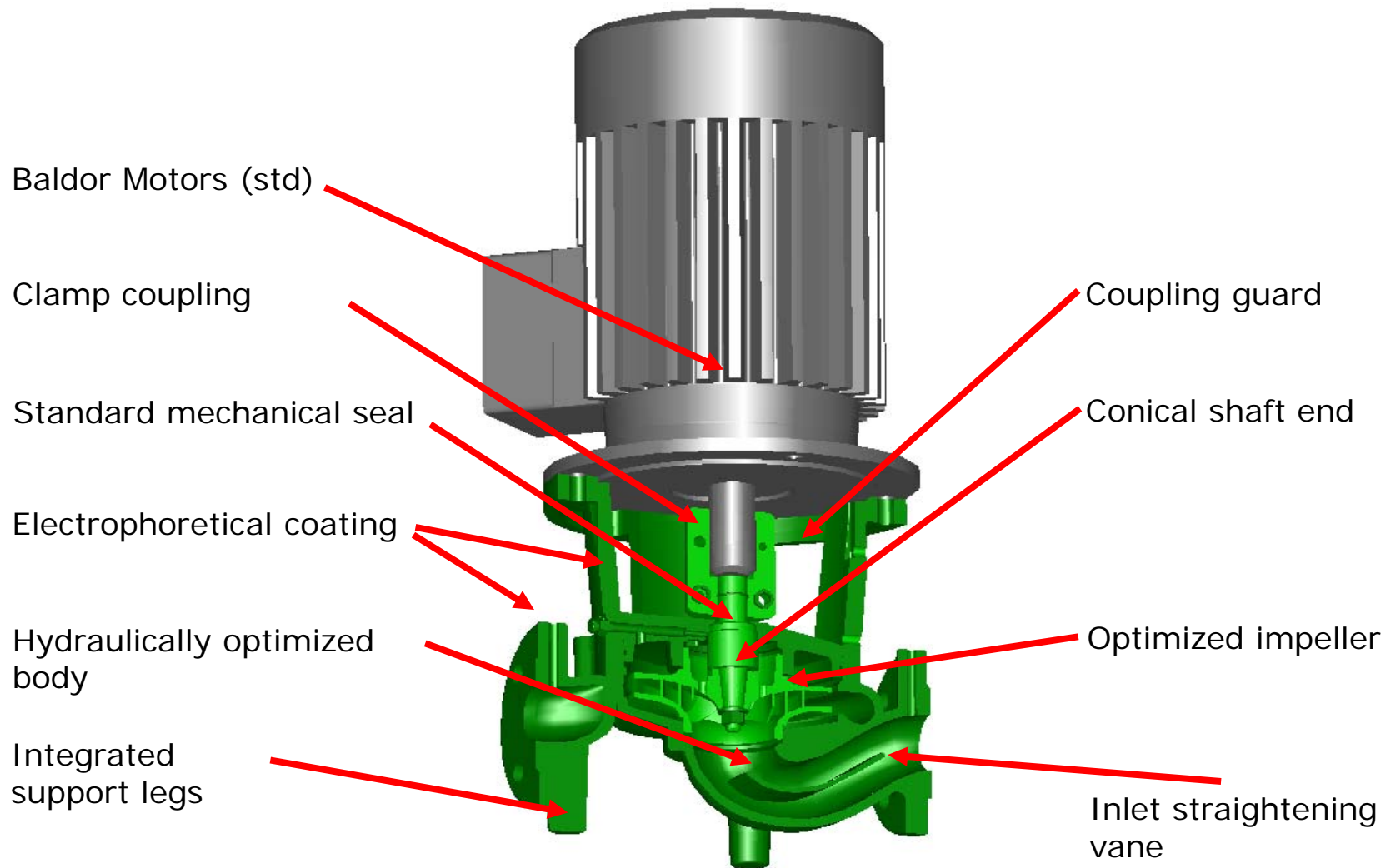

## Detailed Technical Features

**Final finish of the complete pump:**  
2-part epoxy paint

**Pump body and lantern:**  
with electrophoretical coating

**Pump shaft:**  
stainless steel

**Coupling:**  
Galvanized and yellow –  
chromated (RoHS  
compliant)

**Screws:**  
Dacromet® coating

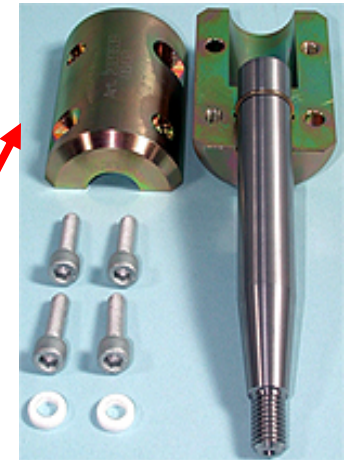
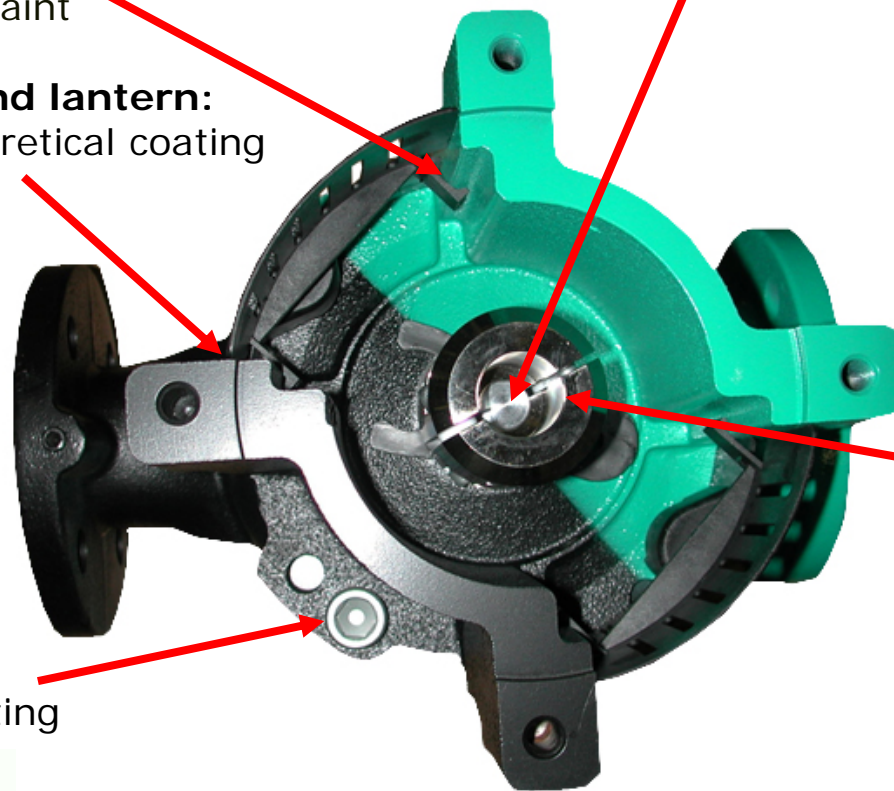

## Installation Instructions

- Install with shaft horizontal or vertical (motor conduit facing up)
- Pump in any direction (vertical, horizontal, etc)
- If pumping vertical try to pump up (with air)
- Locate in system where suction pressure is as high as possible
  - Avoids cavitation
- Pump away from thermal expansion tank!
- Fluid should be relatively free of abrasive particles
  - Causes damage to mechanical seals
- When installing horizontally, read the IOM!
  - Watch motor and mechanical seal air vent orientation
- Do not install at the highest point (air)
- Do not install at the lowest point (dirt)

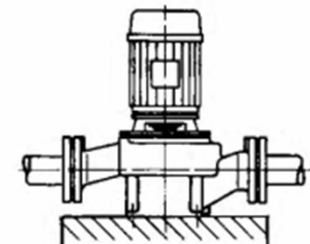
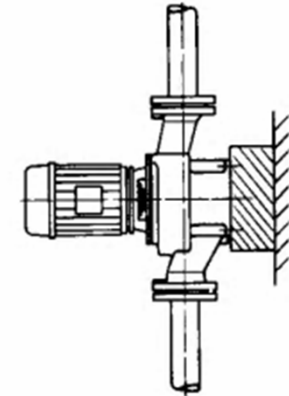
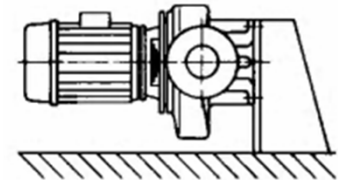

## Installation Instructions

- Be careful with the suction side (laminar flow)
  - Recommendation – 3 pipe diameters or more of straight pipe or device
- Always CHECK ROTATION!

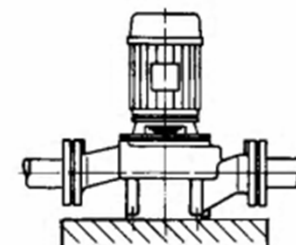
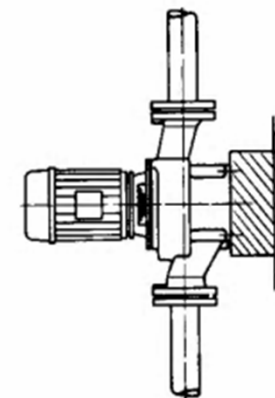
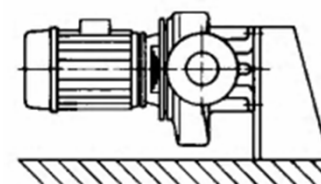



---

## Ordering Information

### Application Type

- Water and/or water/glycol, 50% concentration, 230°F (110°C) max.
  - Use standard Wilo "S1" mechanical seal
- Other applications – contact Wilo

### Application Considerations

- Head and capacity required (especially for custom impeller trimming)
- Available voltage and number of phases (1 or 3)
- Motor Enclosure (dependant of ambient conditions)
  - TEFC standard (for all "flange mount motor types" – C frame)
  - ODP optional
  - Motor efficiency ratings (EISA compliant – Premium or High E)

---

## Questions/Comments?

